



CONVEYORS INC

Quality product moving quality product

**Tower Construction and
Operator/Parts Manual**

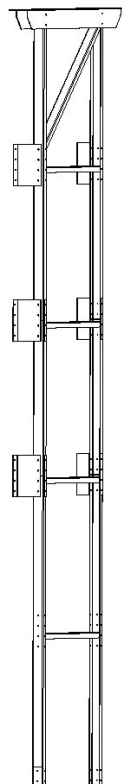

Table of Contents

| | |
|--------------------|----|
| INTRODUCTION | 3 |
| SAFETY | 5 |
| INSTALLATION | 12 |
| PARTS..... | 41 |

Personnel operating or working around this equipment should read this manual. This manual must be delivered with equipment to its owner. Failure to read this manual and its safety instructions is a misuse of the equipment. Any misuse of the equipment may void the warranty.

Introduction

Thank you for purchasing your new Catwalk from KSi Conveyors. We are pleased to have you as a customer, and hope you will enjoy many years of productive service from our products and staff.

Please read and understand this manual before operating the equipment. Pay special attention to the safety information to protect yourself from harm. If you need information beyond what can be found in the manual, please give our friendly staff a call at 888 KSI-CONV.

KSi SAFETY 1ST

Replace missing guards and shields

FREE OF CHARGE!

KSi Conveyors are built to provide many years of dependable service to our customers through durable craftsmanship.

One of the most important aspects of KSi engineering is **SAFETY 1st** design throughout all product lines. At KSi safety is NO ACCIDENT!

That is why KSi is implementing its **SAFETY 1st** program. Should you ever need guards, shields, safety decals or owner/operator manuals, simply contact KSi and we will supply you with them **FREE OF CHARGE!**

If you need any of the above listed safety items or have safety questions, please contact KSi:

454 N State Route 49
Cissna Park IL 60924
Ph: 815-457-2403
888-574-2668

General Information

- A. KSi reserves the right to improve its product whenever possible and practical to do so. We reserve the right to change, improve and modify products at any time without obligation to make changes, improvements and modifications on equipment previously sold.
- B. When receiving merchandise, it is important to check the quantity of parts and their descriptions with the packing list enclosed with each package. All claims for freight damage or shortage must be made with the consignee within ten (10) days from the date of the occurrence of freight damage. The consignee should accept the shipment after noting the damage or loss.
- C. KSi does not make any guarantees on self cleanout or the cross contamination of seed of any kind for their conveyors, Manual cleanout will be required.

TIPS FOR SAFE OPERATION OF KSI CONVEYORS

This Safety Alert symbol means
ATTENTION BECOME ALERT! YOUR SAFETY IS INVOLVED



The Safety Alert symbol identifies important safety messages on KSI conveyors and in the manual. When you see this symbol, be alert to the possibility of personal injury or death. Follow the instructions in the safety message.

Why is SAFETY important?

The Three Best Reasons

Accidents Disable and Kill
Accidents Cost \$\$
Accidents Can be Avoided

SIGNAL WORDS: NOTE THE USE OF SIGNAL WORDS **DANGER**, **WARNING** AND **CAUTION** WITH THE SAFETY MESSAGES. THE APPROPRIATE SIGNAL WORD FOR EACH MESSAGE HAS BEEN SELECTED USING THE FOLLOWING GUIDELINES:

- DANGER -** Indicates an imminently hazardous situation that, if not avoided, will result in death or serious injury. This signal word is to be limited to the most extreme situations, typically for machine components that, for functional purposes, cannot be guarded.
- WARNING -** Indicates a potentially hazardous situation that, if not avoided, could result in death or serious injury, and includes hazards that exposed when guards are removed. It may also be used to alert against unsafe practices.
- CAUTION -** Indicates a potentially hazardous situation that, if not avoided, may result in minor or moderate injury. It may also be used to alert against unsafe practices.

1. General Safety Statements.

- A. KSi's principal concern is your safety and the safety of others associated with grain handling equipment. We want to keep you as a customer. This manual is to help you understand safe operating procedures and some problems which may be encountered by the operator and other personnel.

- B. As the owner and/or operator it is your responsibility to know what requirements, hazards and precautions exist, and to inform all personnel associated with the equipment or are in the area. Safety precautions may be required from the personnel. Avoid any alteration to the equipment. Such alterations may produce a very dangerous situation, where serious injury or death may occur.

- C. This equipment shall be installed in accordance with the current installation codes and applicable regulations which should be carefully followed in all cases. Authorities having jurisdiction should be consulted before installations are made.

- D. Untrained operators subject themselves and other to serious injury or death. NEVER ALLOW untrained personnel to operate this equipment.

- E. Keep children and other unqualified personnel out of the working area at all times.

- F. NEVER start equipment until ALL persons are clear of the work area.

- G. Be sure ALL operators are adequately rested and prepared to perform all functions of operating this equipment.

- H. Keep hair, loose clothing , and shoestrings away from rotating and moving parts. Never wear loose fitting clothing when working around conveyors.

- I. NEVER allow any person intoxicated or under the influence of drugs or alcohol to operate the equipment.

1. General Safety Statements (cont.)

- J. NEVER allow anyone inside a bin, truck, or wagon which is being unloaded by a conveyor. Flowing grain can trap and suffocate in seconds.

- K. Make sure someone is nearby who is aware of the proper shutdown sequence in event of an accident or emergency.

- L. NEVER work alone.

- M. ALWAYS think before acting. NEVER act impulsively around the equipment.

- N. Make sure ALL equipment is locked in position before operating.

- O. Keep hands and feet away from the conveyor intake and other moving parts.

- P. NEVER attempt to assist machinery operation or to remove trash from the equipment while in operation.

- Q. NEVER drive, stand, or walk under the equipment.

- R. Use caution not to hit the conveyor when positioning the load.

- S. Use ample overhead lighting after sunset to light the work area.

- T. ALWAYS lockout ALL power to the equipment when finished unloading the bin.

- U. Keep the area around intake free of obstacles such as electrical cords, blocks, etc. that might trip workers.

A pinch point is any place on the equipment which can injure the operator.

2. Pinch Points.

- A. Components of this equipment have sharp edges which can scrape and/or cut an operator.
- B. A moving conveyor can sever an operator's limb or even kill.

3. Shields and Guards.

- A. Always keep all shields and guards in place during operation.
- B. Missing shields for guards can be replaced for free by contacting KSi.

BEWARE OF ELECTRICAL HAZARDS

Electricity can kill! Use extreme caution around electrical components.

Have your electric company check the transformer and lead wires to be sure they are large enough to handle the additional load of the motor.

Electrical wiring should be done by a qualified electrician and all components shall comply with applicable provisions of National Fire Protection Association Standard NFPA No. 70, American National Standard Inst. ANSI-C1 or with the requirements of the authority of having local jurisdiction.

KSi assumes no responsibility for the electrical wiring used with this machine.

KSi will not be liable for failure of the equipment due to poor or improper electrical power installation.

Wires which are too small deliver insufficient voltage causing the motor to overload or burn out.

Improper or inadequate wiring can kill or cause fires.

All electrical devices used on this machine shall be arranged to operate in a "fail safe" manner, that is, if power failure or failure of device occurs, a hazardous condition must not result. This means, the machine must not restart by itself after a power failure etc. when power returns.

4. Personal Protective Equipment.

A. The proper personal protective equipment should be worn at all times.

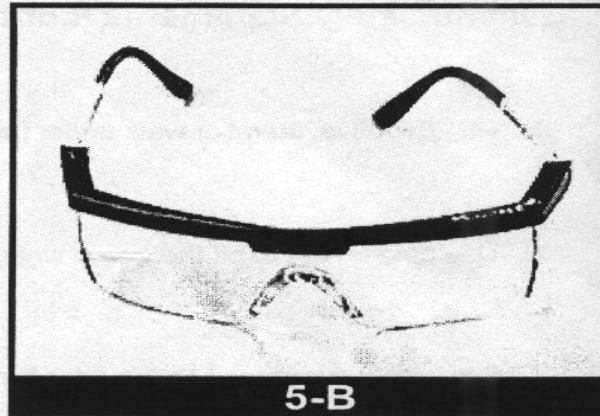

B. ALWAYS wear safety glasses when in the work area.

C. The operator should never wear jewelry.

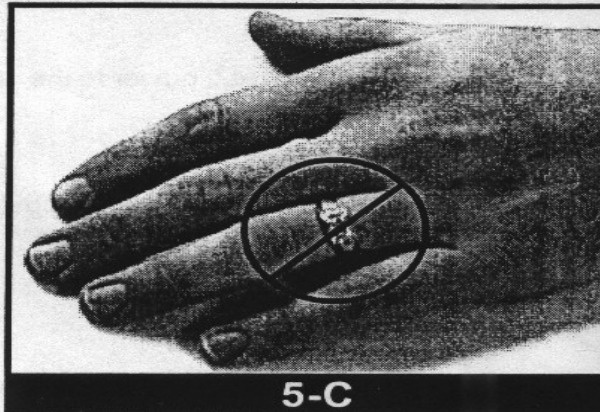

D. Loose clothing should not be worn. Any clothing that becomes loosened should be tucked in tightly.

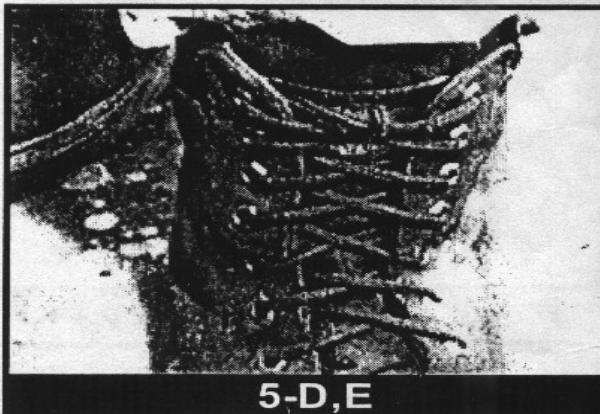

E. Loose or dangling shoe strings should be tucked in.

F. Long hair should be tied up and/or back.

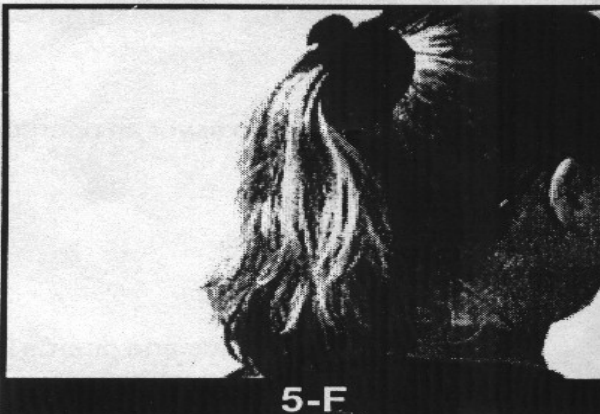

5. Operator Qualifications.

A. The User/Operator must be competent and experienced to operate the equipment. Anyone who works around conveyors must have good common sense in order to be qualified. These persons must also know and meet all other qualifications, such as:

1. Any person who has not read and/or does not understand all operation and safety procedures is not qualified to operate any conveyor systems.
2. Certain regulations apply to personnel operating power machinery. Personnel under the age of 18 years may not operate power machinery, including conveyors. It is your responsibility, as owner and/or supervisor, to know what these regulations are in your area or situation.
3. Unqualified or incompetent persons are to remain out of the work area.
4. O.S.H.A. (Occupational Safety & Health Administration) regulations state:
 “At the time of initial assignment, and at least annually thereafter, the employer shall instruct every employee in the safe operation and servicing of all equipment with which the employee is, or will be, involved.” (Federal Occupational Safety & Health Standards for Agriculture. Subpart D, Section 19287.57 (a) (6).

B. As a requirement of OSHA, it is necessary for the employer to train the employee in the safe operating and safety procedures for this conveyor. We included this sign-off sheet for your convenience and personal record keeping. All unqualified persons are to stay out of the work area at all times. It is recommended that another qualified person who knows the shutdown procedure is in the area in an event of an emergency. A person who has not read this manual and understands all operating and safety instructions is not qualified to operate this machine.

| Date | Employee's name (printed) | Employee's Signature |
|------|---------------------------|----------------------|
| | 1. | |
| | 2. | |
| | 3. | |
| | 4. | |
| | 5. | |
| | 6. | |
| | 7. | |
| | 8. | |
| | 9. | |
| | 10. | |
| | 11. | |
| | 12. | |
| | 13. | |
| | 14. | |
| | 15. | |
| | 16. | |
| | 17. | |



WARNING! Owners and Contractors: Before starting construction of your tower, 1) **READ AND UNDERSTAND THIS MANUAL!** 2) Read and understand the instructions for all equipment, auxiliary equipment, structures, other products, and the like within or connected to this tower system / grain system. 3) View all illustrations in this manual. 4) Read and understand any applicable OSHA Regulations, Building Codes, and Electric Codes.



WARNING! Make certain that all persons working on tower during construction are properly fastened to safety cables to prevent injury or death due to falling.



WARNING! Installation of accessories or equipment in or on the tower that would over stress the structure in any manner will void the Warranty. If you do not have specific recommendations from KSi, where additional loading is involved, please contact KSi before installing any such accessories or equipment.



WARNING! Make certain that all persons within the work area on ladders, lifts, scaffolds, or the like are secure and not in danger of falling! Also make certain that the work surfaces are clean and free of clutter.



WARNING! UNDER NO CIRCUMSTANCES SHALL ANY OTHER BOLT BE SUBSTITUTED FOR THOSE SUPPLIED BY KSi!



WARNING! Any alterations to tower without the authorization of the KSi engineering department is prohibited!



WARNING! Local codes supersede the instructions provided in this manual and should be strictly adhered to. Contact the manufacturer if you have questions.



WARNING! Avoid injury or death! Use extreme caution when working from heights. Use the proper equipment when working from heights. Take the proper precautions to prevent persons or objects from falling!



WARNING! DO NOT substitute parts or hardware for those supplied by KSi.



WARNING! Read and understand all of the instructions in this manual before starting assembly. Build your tower in accordance with the instructions. Failure to build your tower correctly could result in structural damage or failure! Structural damage or failure of any of these assemblies could result in injury or death of persons. Call KSi if you have any questions regarding assembly.



WARNING! Be certain to build your tower in exact accordance with your tower layout!



WARNING! Do not use any damaged tower components. It may not be safe.



WARNING! If you have any problems with construction or if additional wind loading will be added to the catwalk, contact the factory immediately!



WARNING! Do not attempt tower construction when the weather makes it unsafe. Especially, when the wind conditions are not favorable!



WARNING! When adding additional equipment not previously accounted for, considerable wind load or weight may be added to the tower. Be certain that your KSi catwalk is designed and staged for all equipment, and any future additions. If you are uncertain, contact the factory before installing the tower.



WARNING! Pre-position components before field welding. Verify that all installation requirements are satisfied!



WARNING! IMPORTANT: If any question or difficulty should arise during the process of the tower installation, the contractor or owner should contact KSi to get an answer or to resolve the problem!

This page is intentionally left blank.

How to Order Parts

1. Refer to the proper layout view for the area of the machine.
2. Find illustration of the part to be ordered.
3. Note the ITEM number in the balloon point to the part.
4. On the parts list, find the ITEM number listed in the table.
5. Find the Quantity, Part Number, and Description associated with the ITEM number for use when placing your order.

Paint

For matching red paint, use Diamond Vogel IB5588, or equivalent paint.

Order supplies from

KSi Conveyors, Inc.
454 N State Route. 49
Cissna Park, IL 60924
Phone: 815-457-2403
888-574-2668

Abbreviations used in Parts List

AS—Assembly
BKT—Bracket
ITM—Item
LH—Left hand side
NO— Number
OPT—Optional component
QTY—Quantity
RH—Right hand side
AR—As required (e.g. ft. of belt)

(part numbers for stainless conveyors are as shown in illustrations but with XXXXX-8X designation)

TOWER PARTS

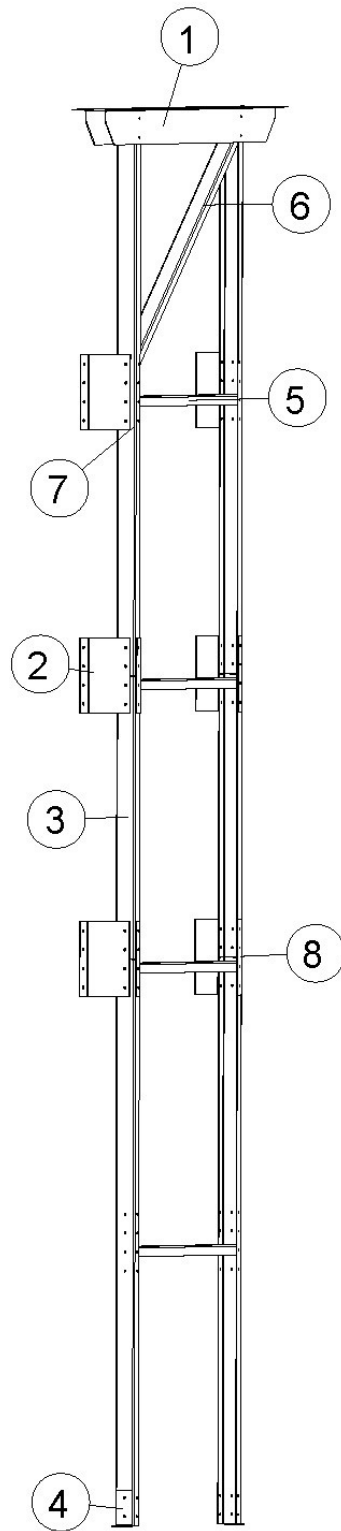

| | 25' | 30' | 33' | 35' | 40' | |
|-----|-----|-----|-----|-----|-----|-------------------------|
| ITM | QTY | QTY | QTY | QTY | QTY | PART NO. |
| 1 | 2 | 2 | 2 | 2 | 2 | KSW001_TOP_CROSS |
| 2 | 6 | 6 | 6 | 8 | 8 | KSW002_WALL_BRACKET |
| 3 | 2 | 0 | 2 | 2 | 0 | KSW012_SIDERAIL_60 |
| 4 | 2 | 2 | 2 | 2 | 2 | KSW024_BASE_FOOT |
| 5 | 4 | 5 | 6 | 6 | 7 | WCB02_CROSS_BRACE |
| 6 | 1 | 1 | 2 | 1 | 1 | WDB01_DIAGONAL_BRACE |
| 7 | 4 | 6 | 4 | 6 | 8 | WMS12_WALL_SIDERAIL |
| 8 | 8 | 8 | 12 | 12 | 12 | WSP01_WALL_SPLICE_PLATE |
| * | 0 | 0 | 2 | 0 | 0 | KSW022_SIDERAIL_96 |

ASSEMBLY INSTRUCTIONS

1. Towers should be put together like previous page using 7/16 bolts and nuts. Torque them like the diagram on page 18.
2. These are 25 ft towers on 25 ft bins. The top of the towers should be the same height of the top of the bin fill lid.
3. You need one more tower than the number of bins you have.
4. Consult customers seed site layout drawing for location of towers on bins.
5. Place the towers on one side of the bin with the edge of the towers on a imaginary line running through the center of the bins.
6. Place the other towers on the other bins in position per the customer site layout drawing.
7. The towers should be anchored in the concrete with 1/2" redhead type anchor bolts.
8. Anchor towers to bins with self threading 3/8"-16 screws provided. Drill a 5/16" pilot hole prior to inserting screws. Silicone behind tower mounts for best prevent of water ingress at bolted joint to bin.
9. Lower the top plate of the tower when it is higher than the side of the seed bins eave. New holes may have to be drilled in the tower structure for relocating the plates.
10. When complete, the side view of the bins and towers should look like Diagram 2 for example.

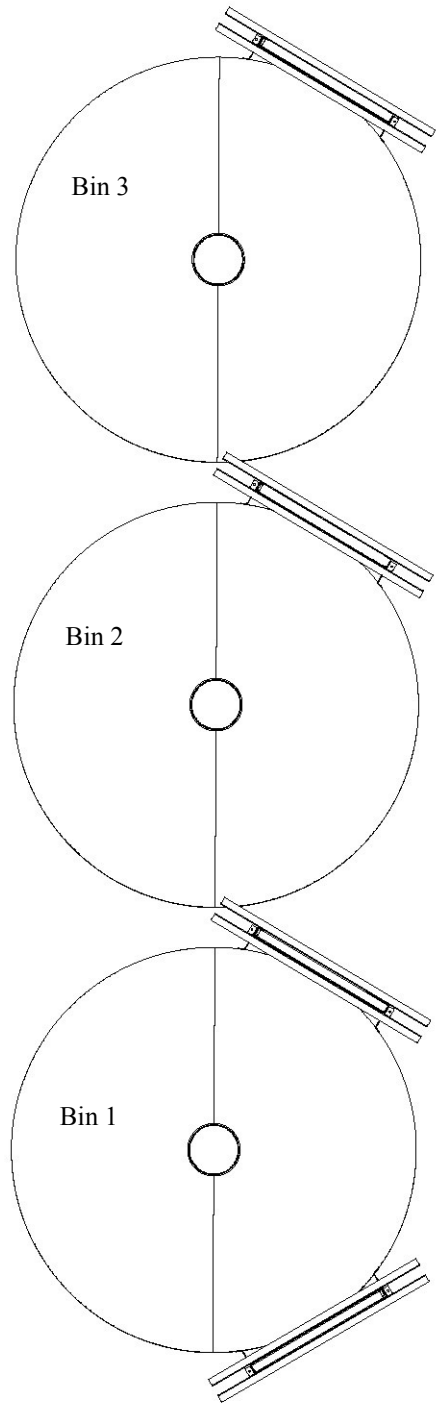

Diagram 1

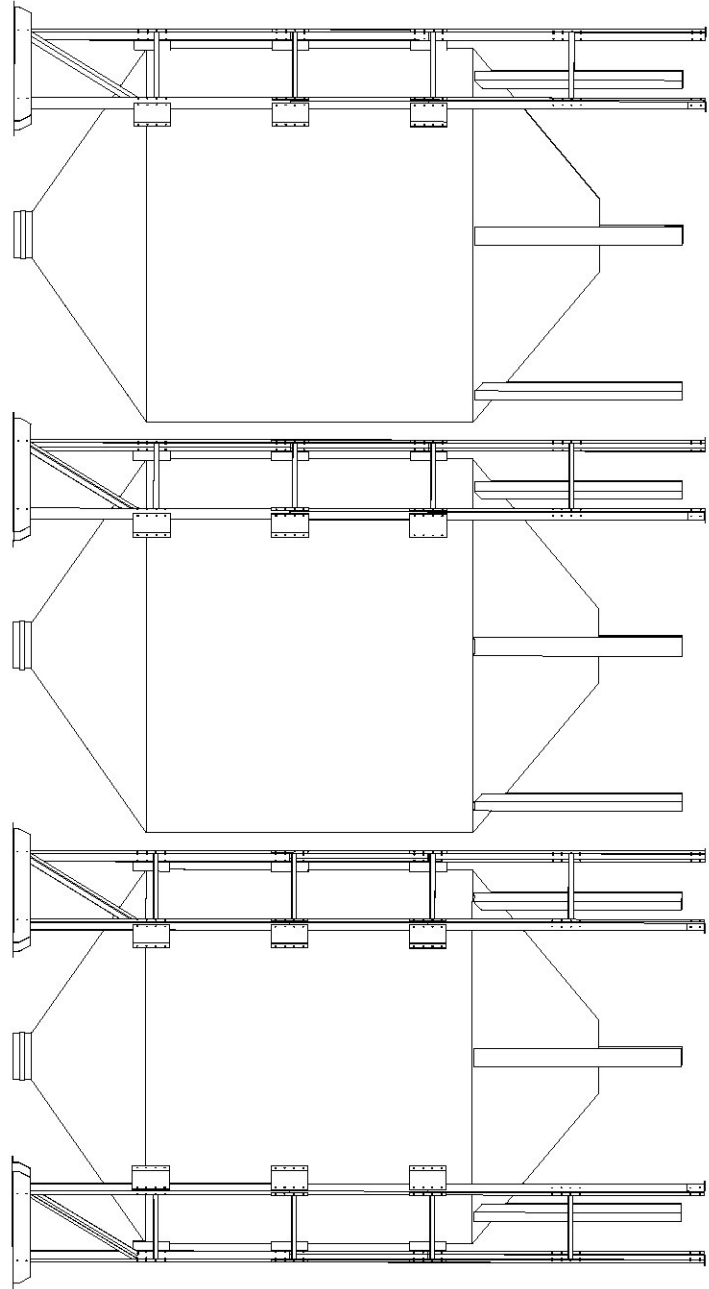

Diagram 2

Bolt torque specifications

Proper torquing of bolts, cap screws, studs, and nuts is very important when assembling or installing any component on a machine. The chart below lists bolt torques for most popular sizes of bolts. The chart also applies to tightening studs or tightening nuts. Refer to the chart whenever a bolt must be tightened on a machine.

Two columns of figures are shown for each type of bolt, dry and lubricated. The “dry” column would cover bolts as they come from the package or bolts with no external lubrication applied. The second column covers bolts externally lubricated with oil, white lead, anti-seize, graphite, etc. This column should also be used to tighten bolts that are being loctite applied.

| Diameter No. Threads | Grade 8 | | | | Grade 5 | | | |
|-------------------------|------------|-------|-------------|-------|------------|-------|-------------|-------|
| | Dry Torque | | Lub. Torque | | Dry Torque | | Lub. Torque | |
| | lbf-ft | N-m | lbf-ft | N-m | lbf-ft | N-m | lbf-ft | N-m |
| 4-40 | 12 | 1 | 9 | 1 | 8 | 0.9 | 6 | 0.6 |
| 6-32 | 23 | 2 | 17 | 1 | 16 | 1 | 12 | 1 |
| 8-32 | 41 | 4 | 31 | 3 | 30 | 3 | 22 | 2 |
| 10-24 | 60 | 6 | 45 | 5 | 43 | 4 | 32 | 3 |
| 1/4-20 | 144 | 16 | 108 | 12 | 96 | 10 | 75 | 8 |
| | lbf-ft | N-m | lbf-ft | N-m | lbf-ft | N-m | lbf-ft | N-m |
| 5/16-18 | 25 | 33 | 18 | 24 | 17 | 23 | 13 | 17 |
| 3/8-16 | 45 | 61 | 35 | 47 | 30 | 40 | 23 | 31 |
| 7/16-14 | 70 | 94 | 55 | 74 | 50 | 67 | 35 | 47 |
| 1/2-13 | 110 | 149 | 80 | 108 | 75 | 101 | 55 | 74 |
| 9/16-12 | 150 | 203 | 110 | 149 | 110 | 149 | 80 | 108 |
| 5/8-11 | 220 | 298 | 170 | 230 | 150 | 203 | 110 | 149 |
| 3/4-10 | 380 | 515 | 280 | 379 | 260 | 352 | 200 | 271 |
| 7/8-9 | 600 | 813 | 460 | 623 | 420 | 583 | 320 | 433 |
| 1-8 | 900 | 1,220 | 680 | 922 | 640 | 867 | 480 | 650 |
| 1 1/8-7 | 1,280 | 1,735 | 960 | 1,301 | 800 | 1,084 | 600 | 813 |
| 1 1/4-7 | 1,820 | 2,467 | 1,360 | 1,844 | 1,120 | 1,518 | 840 | 1,139 |
| 1 3/8-6 | 2,380 | 3,227 | 1,780 | 2,413 | 1,460 | 1,979 | 1,100 | 1,491 |
| 1 1/2-6 | 3,160 | 4,284 | 2,360 | 3,200 | 1,940 | 2,630 | 1,460 | 1,979 |

This page is intentionally left blank.