



CONVEYORS INC

Quality product moving quality product

**Model 1212 Series 1 Inclinor
Operator/Parts Manual**

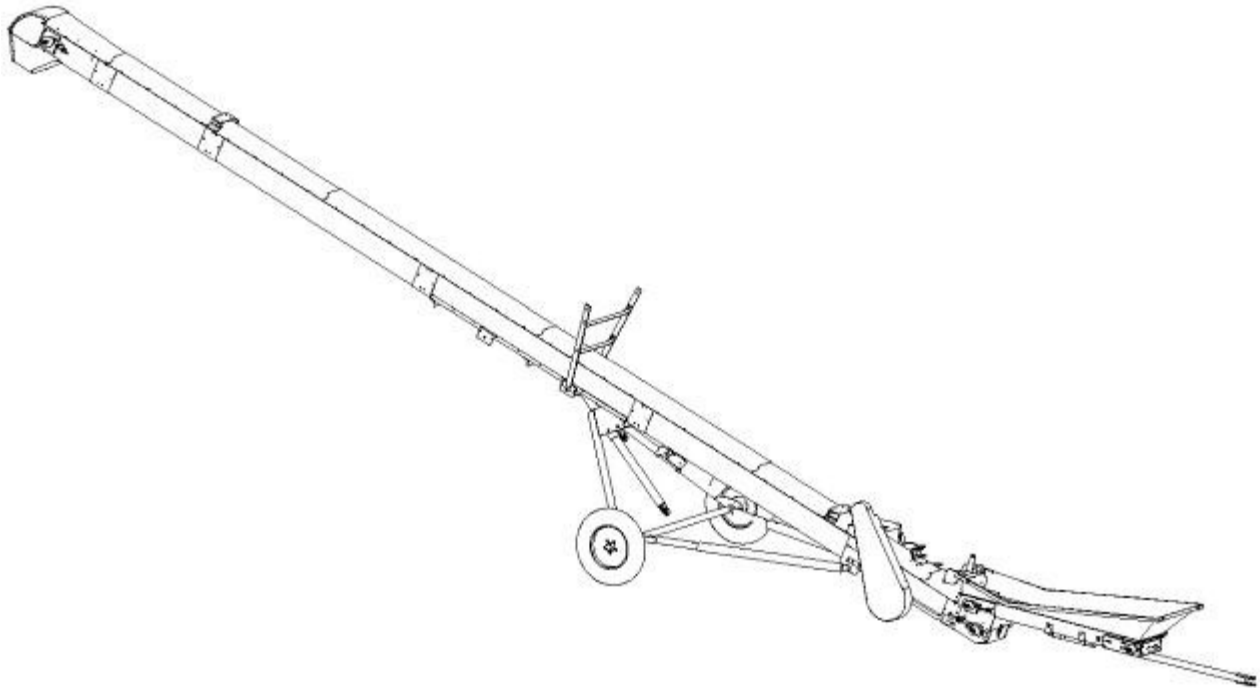

Table of Contents

INTRODUCTION.....	3
WARRANTY.....	4
SAFETY	5
ASSEMBLY OF CONVEYOR BELT	11
INSTALLATION.....	12
INSTALLING SAFETY SIGNS.....	13
OPERATION.....	21
MAINTENANCE.....	23
TROUBLESHOOTING	25
PARTS	27
CONVEYOR ASSEMBLY	28
CONVEYOR BODY	30
LOWER END GROUP.....	34
LOWER END GROUP SCT	36
UPPER END GROUP.....	38
UPPER END GROUP SCT	39
HOPPER GROUP (COLLAPSIBLE).....	40
MOTOR GROUP (HYDRAULIC).....	41
MOTOR GROUP (ELECTRIC)	42
DIMENSIONS	43
SPECIFICATIONS.....	44

Personnel operating or working around this equipment should read this manual. This manual must be delivered with equipment to its owner. Failure to read this manual and its safety instructions is a misuse of the equipment. Any misuse of the equipment may void the warranty.

Introduction

Thank you for purchasing your new Series 1 Model 1212 conveyor from KSi Conveyors. We are pleased to have you as a customer, and hope you will enjoy many years of productive service from our products and staff.

Please read and understand this manual before operating the equipment. Pay special attention to the safety information to protect yourself from harm. If you need information beyond what can be found in the manual, please give our friendly staff a call at 888 KSI-CONV.

KSi SAFETY **1ST**

Replace missing guards and shields
FREE OF CHARGE!

KSi Conveyors are built to provide many years of dependable service to our customers through durable craftsmanship.

One of the most important aspects of KSi engineering is **SAFETY 1st** design throughout all product lines. At KSi safety is NO ACCIDENT!

That is why KSi is implementing its **SAFETY 1st** program. Should you ever need guards, shields, safety decals or owner/operator manuals, simply contact KSi and we will supply you with them **FREE OF CHARGE!**

If you need any of the above listed safety items or have safety questions, please contact KSi:

454 N State Route 49
Cissna Park IL 60924
Ph: 815-457-2403
888-574-2668

General Information

- A. KSi reserves the right to improve its product whenever possible and practical to do so. We reserve the right to change, improve and modify products at any time without obligation to make changes, improvements and modifications on equipment previously sold.
- B. When receiving merchandise, it is important to check the quantity of parts and their descriptions with the packing list enclosed with each package. All claims for freight damage or shortage must be made with the consignee within ten (10) days from the date of the occurrence of freight damage. The consignee should accept the shipment after noting the damage or loss.
- C. KSi does not make any guarantees on self cleanout or the cross contamination of seed of any kind for their conveyors, Manual cleanout will be required.

Limited Warranty

KSi CONVEYORS, INC. ("KSi") WARRANTS ALL PRODUCTS MANUFACTURED BY KSi TO BE FREE OF DEFECTS IN MATERIAL AND WORKMANSHIP UNDER NORMAL USAGE AND CONDITIONS FOR A PERIOD OF 12 MONTHS AFTER RETAIL SALE TO THE ORIGINAL END USER OF SUCH PRODUCTS. KSi's ONLY OBLIGATIONS ARE, AND PURCHASER'S SOLE REMEDY SHALL BE FOR KSi, TO REPAIR OR REPLACE, AT KSi's OPTION AND EXPENSE, PRODUCTS THAT IN KSi's SOLE JUDGMENT, CONTAIN A MATERIAL DEFECT DUE TO MATERIALS OR WORKMANSHIP. ALL DELIVERY AND SHIPMENT CHARGES TO AND FROM THE KSi's FACTORY WILL BE THE PURCHASER'S RESPONSIBILITY. EXPENSES INCURRED BY OR ON BEHALF OF THE PURCHASER WITHOUT PRIOR WRITTEN AUTHORIZATION FROM AN AUTHORIZED EMPLOYEE OF KSi SHALL BE THE SOLE RESPONSIBILITY OF THE PURCHASER.

EXCEPT FOR THE ABOVE STATED EXPRESS LIMITED WARRANTIES, KSi MAKES NO WARRANTY OF ANY KIND, EXPRESSED OR IMPLIED INCLUDING, WITHOUT LIMITATION, WARRANTIES OF MERCHANTABILITY OR FITNESS FOR A PARTICULAR PURPOSE OR USE IN CONNECTION WITH (I) PRODUCT MANUFACTURED OR SOLD BY KSi OR (II) ANY ADVICE, INSTRUCTION, RECOMMENDATION OR SUGGESTION PROVIDED BY AN AGENT, REPRESENTATIVE OR EMPLOYEE OF KSi REGARDING OR RELATED TO THE CONFIGURATION, INSTALLATION, LAYOUT, AND SUITABILITY FOR A PARTICULAR PURPOSE OR DESIGN OF SUCH PRODUCT OR PRODUCTS.

IN NO EVENT SHALL KSi BE LIABLE FOR ANY DIRECT, INDIRECT, INCIDENTAL OR CONSEQUENTIAL DAMAGES, INCLUDING, WITHOUT LIMITATION, LOSS OF ANTICIPATED PROFITS OF BENEFITS. PURCHASER'S SOLE AND EXCLUSIVE REMEDY SHALL BE LIMITED TO THAT STATED ABOVE, WHICH SHALL NOT EXCEED THE AMOUNT PAID FOR THE PRODUCT PURCHASED. THIS WARRANTY IS NOT TRANSFERRABLE AND APPLIES ONLY TO THE ORIGINAL PURCHASER. KSi SHALL HAVE NO OBLIGATION OR RESPONSIBILITY FOR ANY REPRESENTATIVE OR WARRANTIES MADE BY OR ON BEHALF OF ANY DEALER, AGENT, OR DISTRIBUTOR OF KSi.

KSi ASSUMES NO RESPONSIBILITY FOR FIELD MODIFICATIONS OR ERECTION DEFECTS WHICH CREATE STRUCTURAL OR STORAGE QUALITY PROBLEMS. MODIFICATIONS TO THE PRODUCT NOT SPECIFICALLY COVERED BY THE CONTENTS OF THIS MANUAL WILL NULLIFY ANY PRODUCT WARRANTY THAT MIGHT HAVE OTHERWISE BEEN AVAILABLE.

THE FOREGOING WARRANTY SHALL NOT COVER PRODUCTS OR PARTS WHICH HAVE BEEN DAMAGED BY NEGLIGENT USE, MISUSE, ALTERATION, OR ACCIDENT. THIS WARRANTY COVERS ONLY PRODUCTS MANUFACTURED BY KSi. THIS WARRANTY IS EXCLUSIVE AND IN LIEU OF ALL OTHER WARRANTIES EXPRESSED OR IMPLIED. KSi RESERVES THE RIGHT TO MAKE DESIGN OR SPECIFICATION CHANGES AT ANY TIME.

IN NO EVENT SHALL KSi BE LIABLE FOR ANY CROSS CONTAMINATION OF ANY SEED OR MATERIALS USED IN THE CONVEYOR. PRIOR TO INSTALLATION, PURCHASER HAS THE RESPONSIBILITY TO RESEARCH AND COMPLY WITH ALL FEDERAL, STATE, AND LOCAL CODES WHICH MAY APPLY TO THE LOCATION AND INSTALLATION.

TIPS FOR SAFE OPERATION OF KSI CONVEYORS

This Safety Alert symbol means
ATTENTION BECOME ALERT! YOUR SAFETY IS INVOLVED



The Safety Alert symbol identifies important safety messages on KSI conveyors and in the manual. When you see this symbol, be alert to the possibility of personal injury or death. Follow the instructions in the safety message.

Why is SAFETY important?

The Three Best Reasons

Accidents Disable and Kill
Accidents Cost \$\$
Accidents Can be Avoided

SIGNAL WORDS: NOTE THE USE OF SIGNAL WORDS **DANGER**, **WARNING** AND **CAUTION** WITH THE SAFETY MESSAGES. THE APPROPRIATE SIGNAL WORD FOR EACH MESSAGE HAS BEEN SELECTED USING THE FOLLOWING GUIDELINES:

DANGER - Indicates an imminently hazardous situation that, if not avoided, will result in death or serious injury. This signal word is to be limited to the most extreme situations, typically for machine components that, for functional purposes, cannot be guarded.

WARNING - Indicates a potentially hazardous situation that, if not avoided, could result in death or serious injury, and includes hazards that exposed when guards are removed. It may also be used to alert against unsafe practices.

CAUTION - Indicates a potentially hazardous situation that, if not avoided, may result in minor or moderate injury. It may also be used to alert against unsafe practices.

1. General Safety Statements.

- A. KSi's principal concern is your safety and the safety of others associated with grain handling equipment. We want to keep you as a customer. This manual is to help you understand safe operating procedures and some problems which may be encountered by the operator and other personnel.

- B. As the owner and/or operator it is your responsibility to know what requirements, hazards and precautions exist, and to inform all personnel associated with the equipment or are in the area. Safety precautions may be required from the personnel. Avoid any alteration to the equipment. Such alterations may produce a very dangerous situation, where serious injury or death may occur.

- C. This equipment shall be installed in accordance with the current installation codes and applicable regulations which should be carefully followed in all cases. Authorities having jurisdiction should be consulted before installations are made.

- D. Untrained operators subject themselves and other to serious injury or death. NEVER ALLOW untrained personnel to operate this equipment.

- E. Keep children and other unqualified personnel out of the working area at all times.

- F. NEVER start equipment until ALL persons are clear of the work area.

- G. Be sure ALL operators are adequately rested and prepared to perform all functions of operating this equipment.

- H. Keep hair, loose clothing, and shoestrings away from rotating and moving parts. Never wear loose fitting clothing when working around conveyors.

- I. NEVER allow any person intoxicated or under the influence of drugs or alcohol to operate the equipment.

1. General Safety Statements (cont.)

- J. NEVER allow anyone inside a bin, truck, or wagon which is being unloaded by a conveyor. Flowing grain can trap and suffocate in seconds.
- K. Make sure someone is nearby who is aware of the proper shutdown sequence in event of an accident or emergency.
- L. NEVER work alone.
- M. ALWAYS think before acting. NEVER act impulsively around the equipment.
- N. Make sure ALL equipment is locked in position before operating.
- O. Keep hands and feet away from the conveyor intake and other moving parts.
- P. NEVER attempt to assist machinery operation or to remove trash from the equipment while in operation.
- Q. NEVER drive, stand, or walk under the equipment.
- R. Use caution not to hit the conveyor when positioning the load.
- S. Use ample overhead lighting after sunset to light the work area.
- T. ALWAYS lockout ALL power to the equipment when finished unloading the bin.
- U. Keep the area around intake free of obstacles such as electrical cords, blocks, etc. that might trip workers.
-

2. Emergency Shutdown Sequence.

See Emergency Shutdown on page 19 under the operation section.

A pinch point is any place on the equipment which can injure the operator.

3. Pinch Points.

- A. Components of this equipment have sharp edges which can scrape and/or cut an operator.
- B. A moving conveyor can sever an operator's limb or even kill.

4. Shields and Guards.

- A. Always keep all shields and guards in place during operation.
- B. Missing shields for guards can be replaced for free by contacting KSi.

BEWARE OF ELECTRICAL HAZARDS

Electricity can kill! Use extreme caution around electrical components.

Have your electric company check the transformer and lead wires to be sure they are large enough to handle the additional load of the motor.

Electrical wiring should be done by a qualified electrician and all components shall comply with applicable provisions of National Fire Protection Association Standard NFPA No. 70, American National Standard Inst. ANSI-C1 or with the requirements of the authority of having local jurisdiction.

KSi assumes no responsibility for the electrical wiring used with this machine.

KSi will not be liable for failure of the equipment due to poor or improper electrical power installation.

Wires which are too small deliver insufficient voltage causing the motor to overload or burn out.

Improper or inadequate wiring can kill or cause fires.

All electrical devices used on this machine shall be arranged to operate in a "fail safe" manner, that is, if power failure or failure of device occurs, a hazardous condition must not result. This means, the machine must not restart by itself after a power failure etc. when power returns.

5. Personal Protective Equipment.

A. The proper personal protective equipment should be worn at all times.

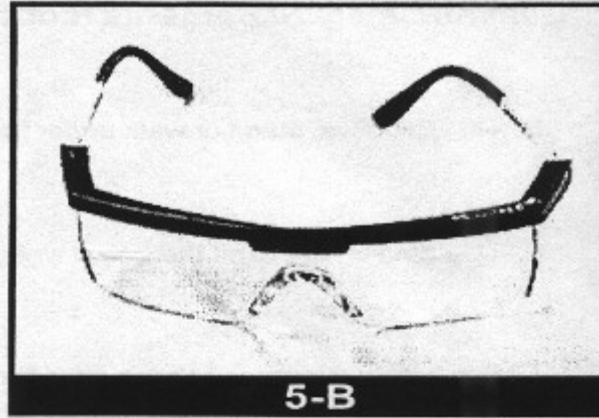

B. ALWAYS wear safety glasses when in the work area.

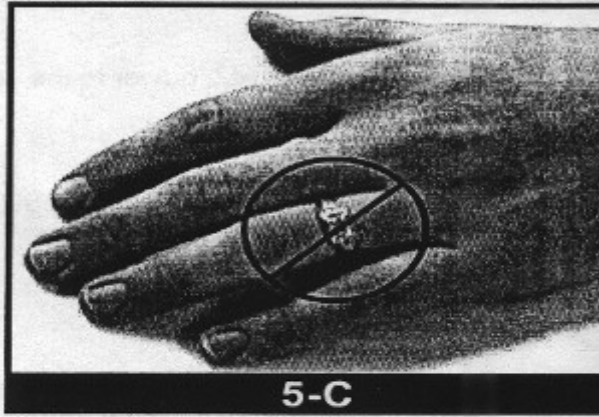

C. The operator should never wear jewelry.

D. Loose clothing should not be worn. Any clothing that becomes loosened should be tucked in tightly.

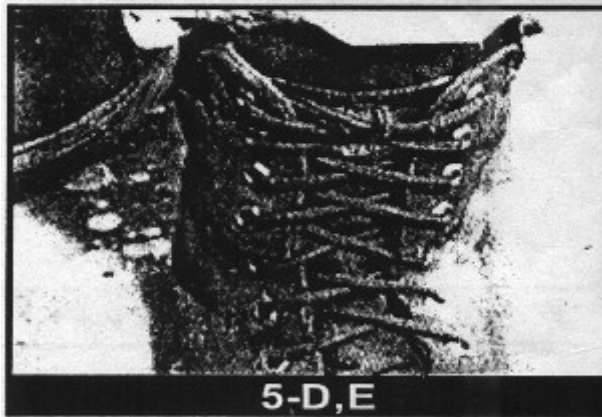

E. Loose or dangling shoe strings should be tucked in.

F. Long hair should be tied up and/or back.

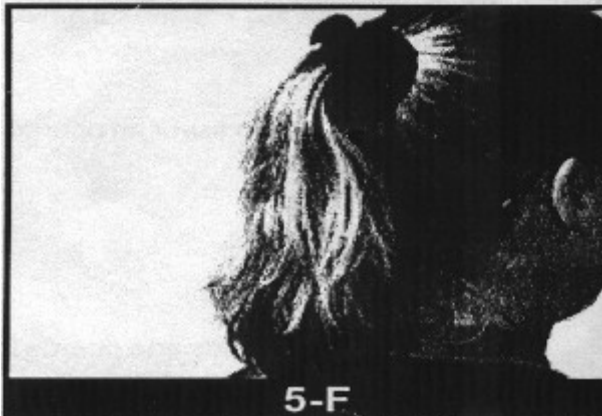

6. Operator Qualifications.

- A. The User/Operator must be competent and experienced to operate the equipment. Anyone who works around conveyors must have good common sense in order to be qualified. These persons must also know and meet all other qualifications, such as:
1. Any person who has not read and/or does not understand all operation and safety procedures is not qualified to operate any conveyor systems.
 2. Certain regulations apply to personnel operating power machinery. Personnel under the age of 18 years may not operate power machinery, including conveyors. It is your responsibility, as owner and/or supervisor, to know what these regulations are in your area or situation.
 3. Unqualified or incompetent persons are to remain out of the work area.
 4. O.S.H.A. (Occupational Safety & Health Administration) regulations state:
 “At the time of initial assignment, and at least annually thereafter, the employer shall instruct every employee in the safe operation and servicing of all equipment with which the employee is, or will be, involved.” (Federal Occupational Safety & Health Standards for Agriculture. Subpart D, Section 19287.57 (a) (6).
- B. As a requirement of OSHA, it is necessary for the employer to train the employee in the safe operating and safety procedures for this conveyor. We included this sign-off sheet for your convenience and personal record keeping. All unqualified persons are to stay out of the work area at all times. It is recommended that another qualified person who knows the shutdown procedure is in the area in an event of an emergency. A person who has not read this manual and understands all operating and safety instructions is not qualified to operate this machine.

Date	Employee’s name (printed)	Employee’s Signature
	1.	
	2.	
	3.	
	4.	
	5.	
	6.	
	7.	
	8.	
	9.	
	10.	
	11.	
	12.	
	13.	
	14.	
	15.	
	16.	
	17.	

Assembly of Conveyor Belt

Squaring One End of Belt

Lay a framing square along a straight edge of the belt to make a cut line on the back side of the belt. Cut belt along this line using a utility knife. If the belt has uneven edges, create an average centerline, and square off of this line. **A clean, straight, square cut is required for the belt to run true on the pulleys.**

Installing Belt Splice

1. Center and press the fastener strip on the belt.
2. Press the Application Tool on the center of fastener strip with the cam lever in the “up” position.
3. Lower cam lever. Strike staple driver on each staple until staple clinches on Application Tool anvil.
4. Raise cam lever and move tool to outer edge of belt.
5. Clinch staples. Repeat until all staples are complete.
6. Place the splice over a piece of flat steel and clinch each staple with a hammer. Turn belt over and peen staple ends flush with surface of fastener strip.
7. Bend fastener strips until they break apart.

Installing Belt into the Conveyor

1. Remove the Tail End Door As.
2. Slide a fish tape from the discharge end to the tail end of the conveyor. Pull a rope with a belt splice back through the conveyor. Fasten the conveyor belt to the rope splice, and pull the belt into the top of the conveyor with the rope.
3. Using the fish tape, pull the bottom side of the belt through the conveyor. **Make sure the belt is free of extra twists before pulling it in.**
4. Check to see that the idler is all the way forward (toward the drive end).
5. Pull the belt up tight at the discharge end and cut off the excess length so that there is 1/2” of overlap after the end is squared.
6. Follow the procedure above for installing the second belt splice.
7. Insert the hinge pin. Crimp the pin washers on the ends of the pin using pliers.
8. Tighten the belt tensioning bolts to 23 FT-LBS. so that each side is adjusted equally.
9. Re-assemble the tail end Door As.

Tracking the Belt

1. Basic rule: *the belt moves toward the end of the roller that it contacts first.*
2. Rollers must be square with the housing and parallel to each other.
3. Belt tension must be great enough to prevent slippage. Tension to 23 ft-lbs. on adjustment bolts.



CAUTION: Make sure everyone is clear of machine before running.

5. Run the conveyor. Check to see that the belt runs centered on the drive roller. Turn off the machine. Adjust drive roller if necessary.



WARNING: Do not run the machine while adjusting. Failure to heed may result in personal injury or death.

6. To adjust drive roller, loosen the four nuts on the bearing holder plate, and the jam nut on the threaded adjuster. Retighten after adjusting is complete.



CAUTION: Make sure everyone is clear of machine before running.

7. Run the machine for two minutes. Make sure belt runs centered on drive pulley.
8. Open the Tail End Door to view the idler.
9. Run the machine. Check to see that the belt is running centered on the idler roller. Turn the machine off.



WARNING: Do not run the machine while adjusting. Failure to heed may result in personal injury or death.

10. If adjustment is necessary, adjust the tensioning bolts on the idler housing to 23 ft-lbs torque.
11. Check adjustment by running the machine. Make sure belt runs centered on idler pulley. The clearance between the belt and the housing should be the same on both sides.
12. Close the Tail End Door when complete.

Installing Safety Signs

The Safety Decals listed below are included with the conveyor, the following pages show the location of the decals on the conveyor. Inspect all decals and replace any that are worn, illegible, or missing. Contact your dealer or the factory to order replacement decals.

KS-0008



KS-0002

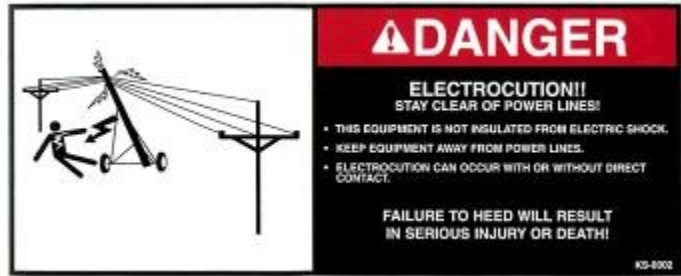

KS-0007

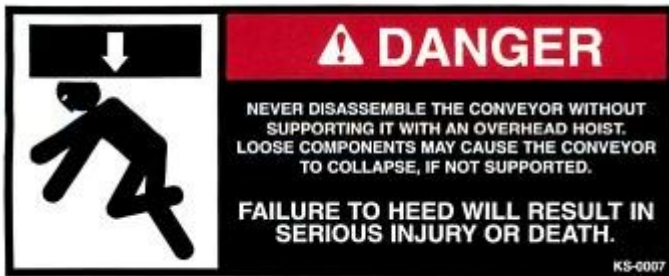

KS-0005

KS-0001

⚠ CAUTION

1. READ AND UNDERSTAND THE INSTALLATION & OPERATION MANUAL AND ALL SAFETY INSTRUCTIONS BEFORE OPERATING EQUIPMENT.
2. DO NOT OPERATE WHILE UNDER THE INFLUENCE OF DRUGS OR ALCOHOL.
3. DO NOT OPERATE UNLESS ALL SAFETY EQUIPMENT, SWITCHES, GUARDS AND SHIELDS ARE SECURELY IN PLACE AND OPERATIONAL.
4. BE SURE EVERYONE IS CLEAR OF THE EQUIPMENT BEFORE ATTEMPTING TO OPERATE OR MOVING THE MACHINE.
5. ALLOW ONLY TRAINED PERSONNEL IN THE OPERATING AREA.
6. KEEP HANDS, FEET, HAIR AND CLOTHING AWAY FROM MOVING PARTS.
7. DISCONNECT AND LOCKOUT POWER BEFORE ADJUSTING OR SERVICING.
8. ELECTRICAL WIRING OR SERVICE WORK MUST BE PERFORMED BY A QUALIFIED ELECTRICIAN. IT MUST MEET ALL STATE AND LOCAL ELECTRICAL CODES.
9. EMPTY CONVEYOR AND LOWER TO TRANSPORT POSITION BEFORE TRANSPORTING.
10. MAKE CERTAIN ALL ELECTRIC MOTORS ARE GROUNDED.
11. NEVER MOVE MACHINE MANUALLY. ALWAYS USE A TOWING VEHICLE.
12. KEEP CHILDREN AWAY FROM THE WORK AREA AT ALL TIMES.

KS-0001

⚠ DANGER



UPENDING OR FALLING CONVEYOR HAZARD

ALWAYS SECURE INTAKE END SO THE CONVEYOR CANNOT FALL OR UPEND.

EMPTY THE CONVEYOR BEFORE ATTEMPTING TO TRANSPORT IT.

NEVER PUSH THE UNDERCARRIAGE. ALWAYS USE PROPER TRANSPORTING METHODS.

USE CAUTION WHEN LIFTING THE INTAKE END. NEVER LIFT HIGHER THAN THE VEHICLE TOW BAR. DO NOT RELEASE UNTIL CONVEYOR IS SECURELY ATTACHED TO THE TOW BAR OR ON THE GROUND.

LOWER THE CONVEYOR FOR TRANSPORTING IMMEDIATELY AFTER MOVING IT AWAY FROM THE STORAGE BIN.

FAILURE TO HEED WILL RESULT IN SERIOUS INJURY OR DEATH!

KS-0005



KS-0010



KS-0017

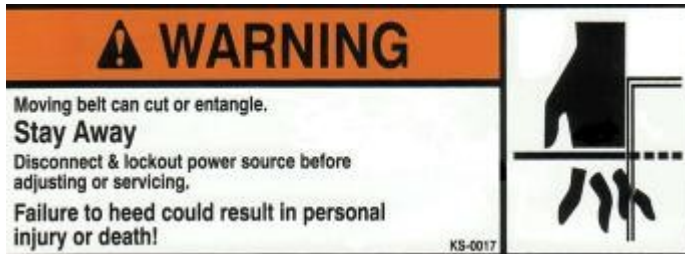

KS-0015



KS-0004



KS-0016





KS-0016



KS-0021



KS-0016





KS-0030



This page is intentionally left blank.

1. Operation Recommendations.

- A. One person must be in a position to monitor the operation of the conveyor at ALL times. That person should visually inspect the conveyor before and during operation and be alert to any unusual vibrations, noises, and loosening of any fasteners.
- B. For smoother startups, keep the conveyor from starting totally full. This will also ensure efficient operation.
- C. In cold weather, run empty conveyor for five minutes to warm up belt. Otherwise, do not operate the conveyor empty for long periods of time.
- D. You must “break-in” the conveyor when it is new and at the beginning of each season. Refer to step 3 for instructions..
- E. Make sure the drive end is empty before shutting down the conveyor.



Do not stop or start the conveyor under load because the belt has a tendency to slip on the drive pulley, especially if the belt and tube have not become well polished.

2. Emergency Shutdown.



IMPORTANT: Do not restart the conveyor when it is loaded. This may damage the conveyor.

- A. If you have to immediately shutdown the conveyor under load, **be sure to disconnect and lockout the power source.**
- B. Remove as much grain as possible from the hopper and the conveyor before restarting.
- C. **Never** attempt to restart the conveyor when it is full.
- D. When as much grain as possible has been cleared from the hopper and the conveyor, reconnect the power source and clear the remaining grain gradually.



Be certain to close ALL clean-out and inspection doors in the main conveyor hopper before operating.

The operator should not add power before viewing the entire work area and checking that ALL personnel are clear of the designated work area.

The operator should be alert to any unusual vibrations or noises that might indicate the need for service or repair during the initial startup and break-in period.

The operator should regulate the grain flow to the main conveyor by controlling the amount of grain fed into the hopper. Avoid plugging the main conveyor by overfeeding the hopper.

Be certain that all safety shields and devices remain in place during operation.

Ensure that hands, feet, and clothing are kept away from moving parts.

Stop the motor and lockout the power source whenever the equipment must be serviced or adjusted.

3. Startup and Break-In

- A. Any conveyor that is new or has set idle for a season needs to go through a “break-in” period.
- B. Run the conveyor at partial capacity until several hundred bushels of grain have been conveyed and the belt and tube are polished.
- C. Retighten belt to restore original belt tension.
- D. Do not run Honda gas powered engines less than 75 percent power. Early clutch failure may occur.

Maintenance

NEVER perform maintenance on the conveyor unless all safety shields are in place. Replace any that are damaged or lost. Do not clean, adjust, or lubricate any part of the machine while it is in operation.

1. Conveyor Belt Adjustment

Belt tension and tracking will need periodic adjustment. Follow the guidelines under “Tracking the Belt” to make adjustments.

IMPORTANT

BELT ALIGNMENT and BELT TENSION should be checked periodically. BELT damage will occur if alignment or tension has not been maintained. BELT tension should be 23 ft. lbs. of torque on adjustment bolts. BELT should be tracked to be centered on the idle and drive roller.

KS-0014



Maintenance Cont.

2. Conveyor Belt Care

- A. It is recommended that the conveyor belt be washed off and the tail end be cleaned out at the end of the season. This will help prevent material residue from building up and causing damage to the belt.
- B. In order for water to drain from the conveyor belt, the splice must be parked on the top side of the circuit. To obtain this condition, open the door at the tail end. Run the conveyor until the belt splice appears. Turn off the conveyor immediately. The splice will now be on the top side.

3. Drive Belts

Inspect the V-belts on the drive system at the beginning and end of each season. If cracks or wear are evident, replace the belts. Belt tension will need periodic adjustment.

4. Lubrication.

- A. Winches require the following maintenance:
 - 1. All gears must be covered by a film of grease at all times.
 - 2. The nut holding the handle assembly must be tight.
 - 3. The two (2) bushings found at the end of the drum shaft, the ratchet pawl, and the bushing at the ends of the pinion shaft should be wet with oil.
 - 4. The teeth of the ratchet lock should be sharp, and not worn, so they can hold the load.
- B. Bearings (25 Hr Interval)
 - 1. Lubricate bearings on belt drive/idler rollers.
 - 2. Lubricate two (2) bearings on transport wheels.
- C. Use a good quality lithium soap base E.P. grease meeting the N.L.G.I. #2 specifications and containing no more than 1% molybdenum disulfide to lubricate all fittings (Example: Shell super duty or equivalent.)

Problem	Possible Cause	Solution
1. The conveyor is vibrating.	A. Damage can occur to the belting, causing a noise. Damage usually is caused from foreign material being run through the conveyor.	A1. It may be necessary to remove the belting for inspection.
	B. The belt is not tracking in the center of the conveyor.	B1. Track the belt.
2. Capacity is too low.	A. There may not be enough grain reaching the conveyor.	A1. Make sure the intake has not bridged over, restricting flow. The belt needs to be covered to achieve maximum capacity.
	B. Conveyor belt is moving too slow.	B1. Check the belt speed. Low capacity will result from speeds slower than recommended. B2. Belt needs tightening.
3. The conveyor plugs.	A. The conveyor may be “jamming” because too much grain is reaching the conveyor.	A1. Decrease the amount of grain the conveyor is gathering.
	B. The grain may be wet.	B1. If wet grain or other hard to move materials is being conveyed, reduce the amount of grain being fed into hopper. B2. On electric drive unit check motor wiring or a higher hp motor is needed.
	C. The conveyor may be jammed with foreign material.	C1. Remove any foreign material in the conveyor.
	D. The discharge end may be plugged.	D1. Unplug any plugs at the discharge end of the conveyor.
	E. Pulley has spun out and burned the belt in two.	E1. Cut and resplice the belt, An additional piece of belting may be required. E2. Tighten and retrack the belt.

Problem	Possible Cause	Solution
4. Cleated belt is slipping or loose.	A. Belt tension too low.	A1. Tension belt to 23 ft-lbs. on the adjustment bolts.
	B. Belt is extremely dirty.	B1. Clean traction side of belt.
5. Cleated belt is rubbing side of housing or cleats are coming loose or wearing.	A. Belt misaligned.	A1. Align belt so its tracks center of idle and drive rollers.

How to Order Parts

1. Refer to the proper layout view for the area of the machine.
2. Find illustration of the part to be ordered.
3. Note the ITEM number in the balloon point to the part.
4. On the parts list, find the ITEM number listed in the table.
5. Find the Quantity, Part Number, and Description associated with the ITEM number for use when placing your order.

Paint

For matching red paint, use Diamond Vogel IB5588, or equivalent paint.

Order supplies from

KSi Conveyors
454 N State Route 49
Cissna Park, IL 60924
Phone: 888-574-2668

Abbreviations used in Parts List

AS—Assembly
BKT—Bracket
ITM—Item
LH—Left hand side
NO— Number
OPT—Optional component
QTY—Quantity
RH—Right hand side

CONVEYOR ASSEMBLY 121234-13

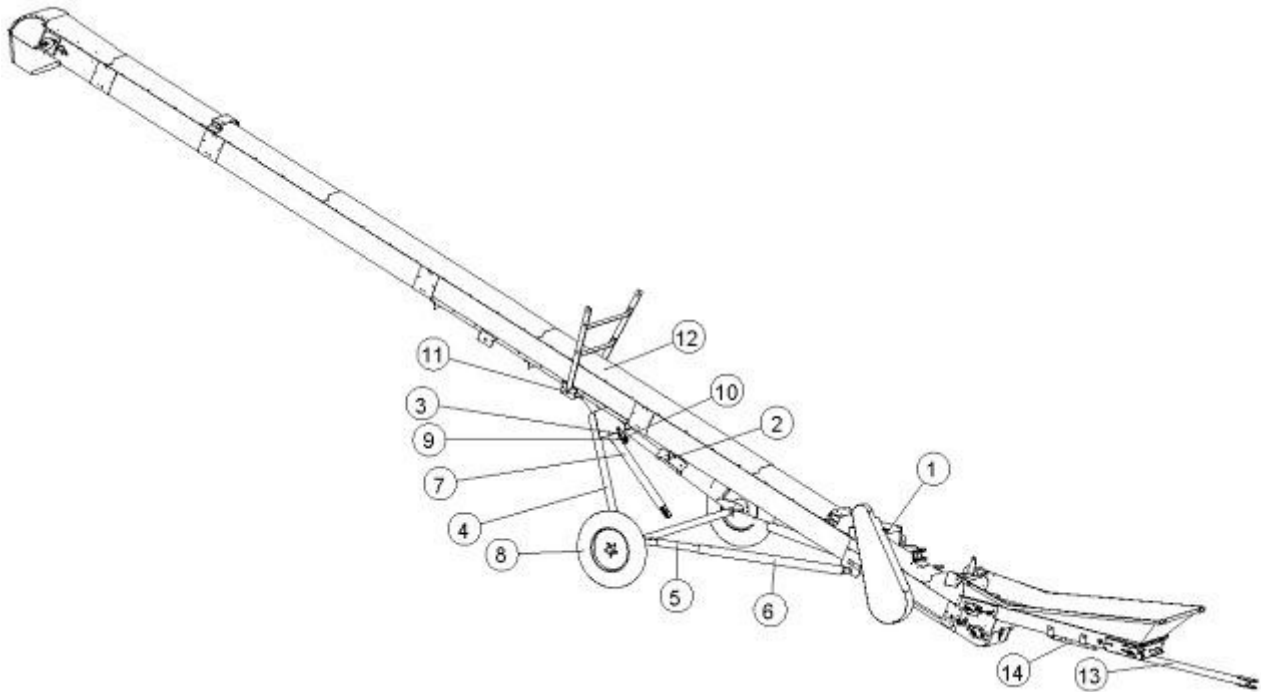

	25sct	30sct	34sct		
ITM	QTY	QTY	QTY	PART NO	NAME
1	1	1	1	21090-05	MOTOR MOUNT, GAS ENGINE
2	1	1	1	21114-07	WINCH (5353)
3	2	2	2	21123-01	STRAP, CABLE PULL
4	1	1	1	21901-01	AXLE A-FRAME ASSEMBLY
5	2	2	2	21914-00	INNER TELESCOPING ARM (44")
6	2	2	2	21915-00	TELESCOPING ARM, OUTER (52")
6	0	0	0	21906-01	FRAME ASSY, LOWER 17' 87.75"
6	0	0	0	21910-00	FRAME as., INCLINATOR 105.75"
6	0	0	0	21912-00	FRAME AS., LOWER, 136"
7	1	1	1	21920-01	FRAME AS. - LIFT
8	2	2	2	24122-01	TIRE AS. (REDNECK 135DW-175W)
9	2	2	2	24124-01	PULLEY, CABLE
10	2	2	2	24175-01	BUSHING, PULLEY
11	1	1	1	24320-01	PIN, PIVOT
12	1	1	1	28101-34	CONVEYOR BODY
13	1	1	1	28220-00	HITCH AS.
14	1	1	1	28221-00	TOWING AS

CONVEYOR ASSEMBLY 121234-10

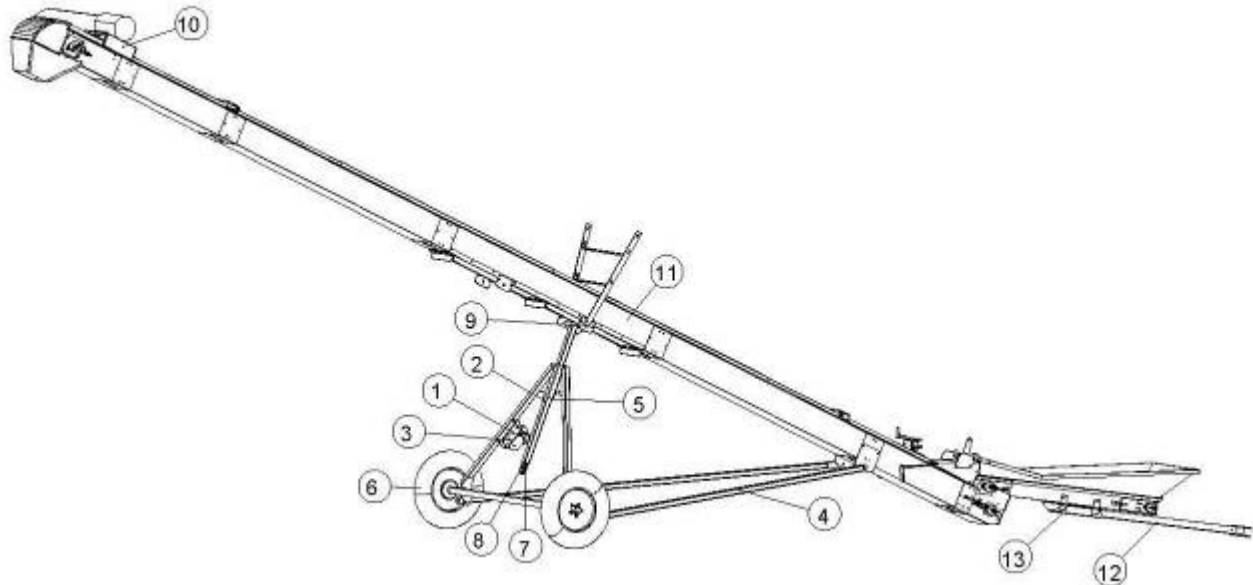

	25E	25H	30E	30H	34E	34H		
ITM	QTY	QTY	QTY	QTY	QTY	QTY	PART NO.	NAME
1	1	1	1	1	1	1	21114-07	WINCH (5353)
2	2	2	2	2	2	2	21123-01	STRAP, CABLE PULL
3	1	1	1	1	1	1	21901-01	AXLE A-FRAME ASSEMBLY
4	2	2	0	2	0	2	21906-01	FRAME ASSY, LOWER 17' 87.75"
	0	0	2	0	0	0	21910-00	FRAME as., INCLINATOR 105.75"
	0	0	0	0	2	0	21912-00	FRAME AS., LOWER, 136"
5	1	1	1	1	1	1	21920-01	FRAME AS. - LIFT
6	2	2	2	2	2	2	24122-01	TIRE AS. (REDNECK 135DW-175W)
7	2	2	2	2	2	2	24124-01	PULLEY, CABLE
8	2	2	2	2	2	2	24175-01	BUSHING, PULLEY
9	1	1	1	1	1	1	24320-01	PIN, PIVOT
10	1	0	1	0	1	0	26120-01	MOTOR GROUP
11	1	1	1	1	1	1	28101-34	CONVEYOR BODY
12	1	1	1	1	1	1	28220-00	HITCH AS.
13	1	1	1	1	1	1	28221-00	TOWING AS

CONVEYOR BODY 28103-34

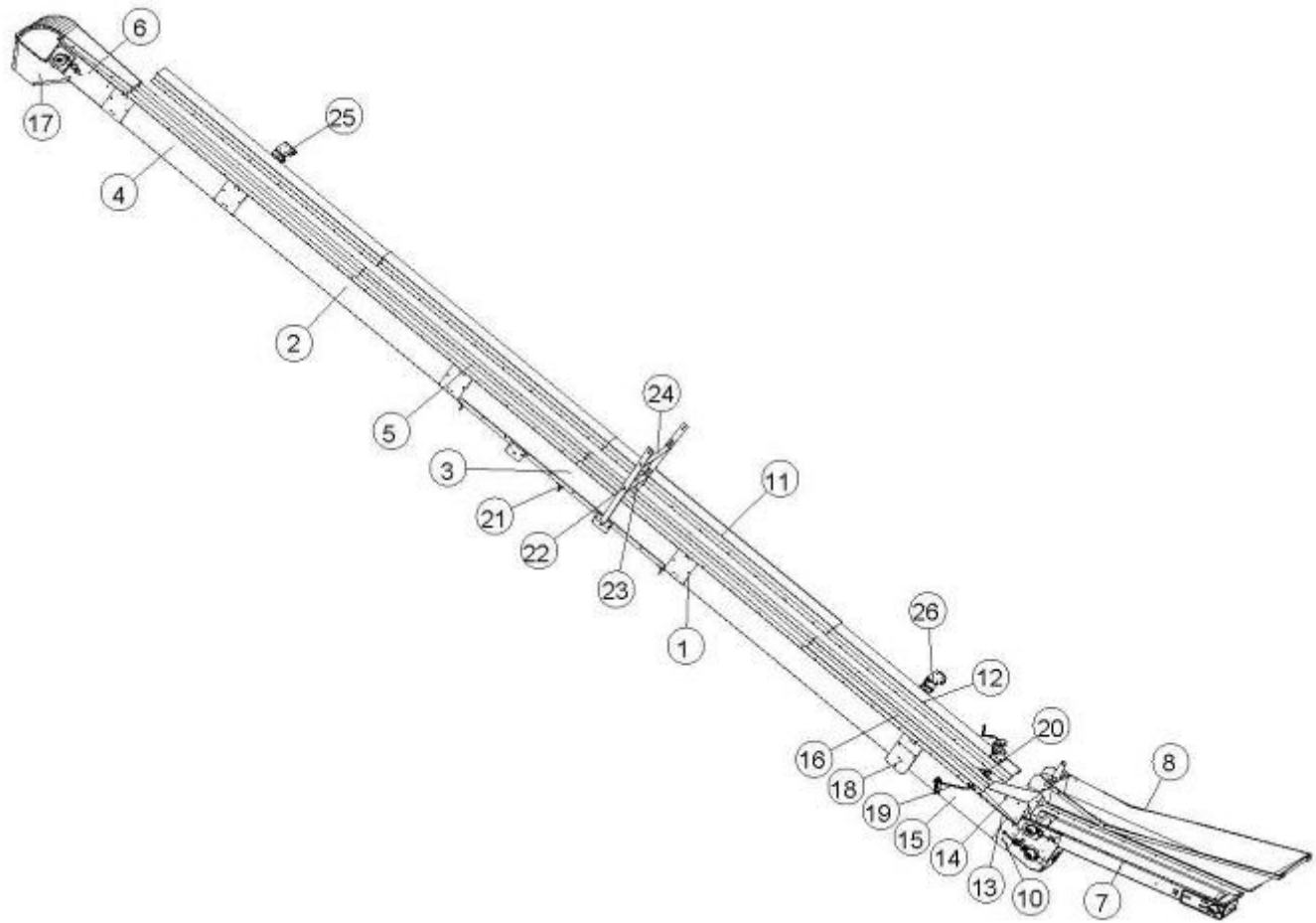

CONVEYOR BODY 28101-34

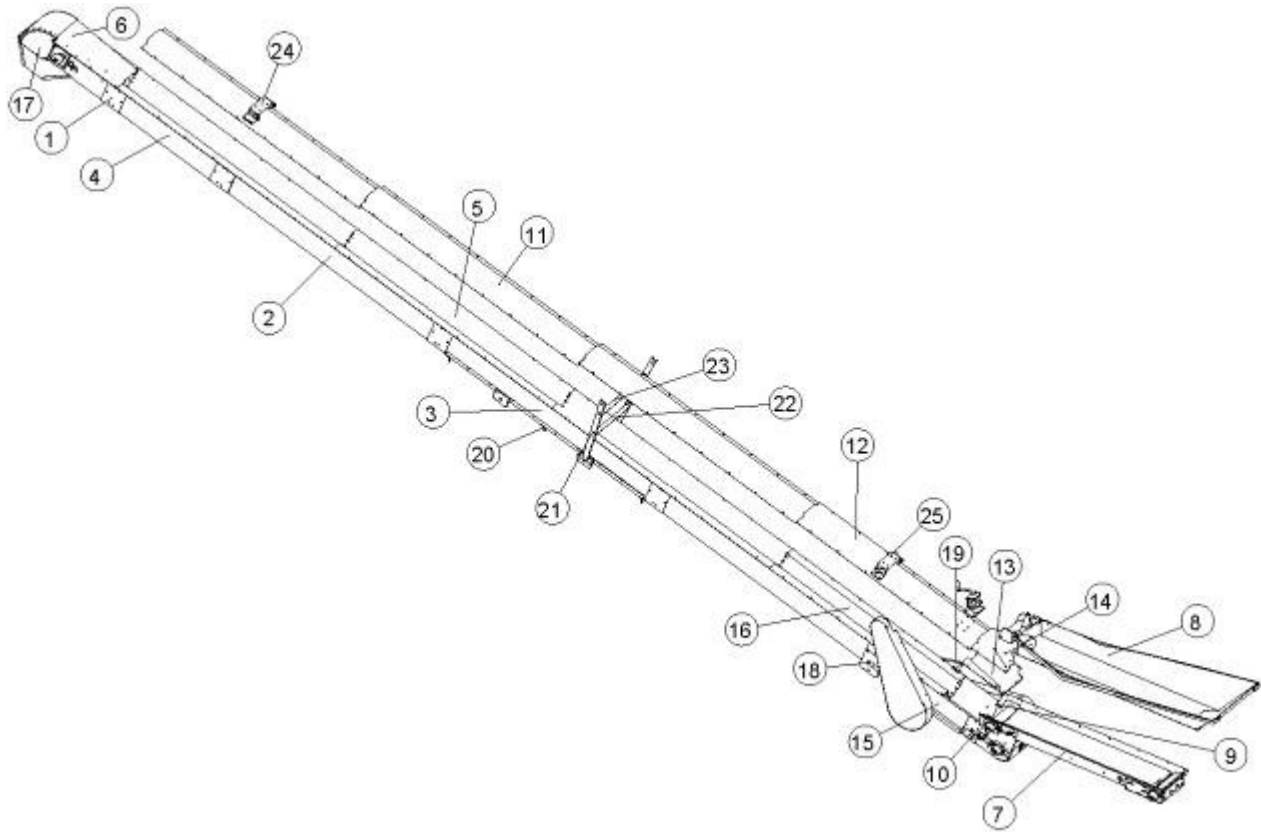

**23200-01
LOWER END GROUP**

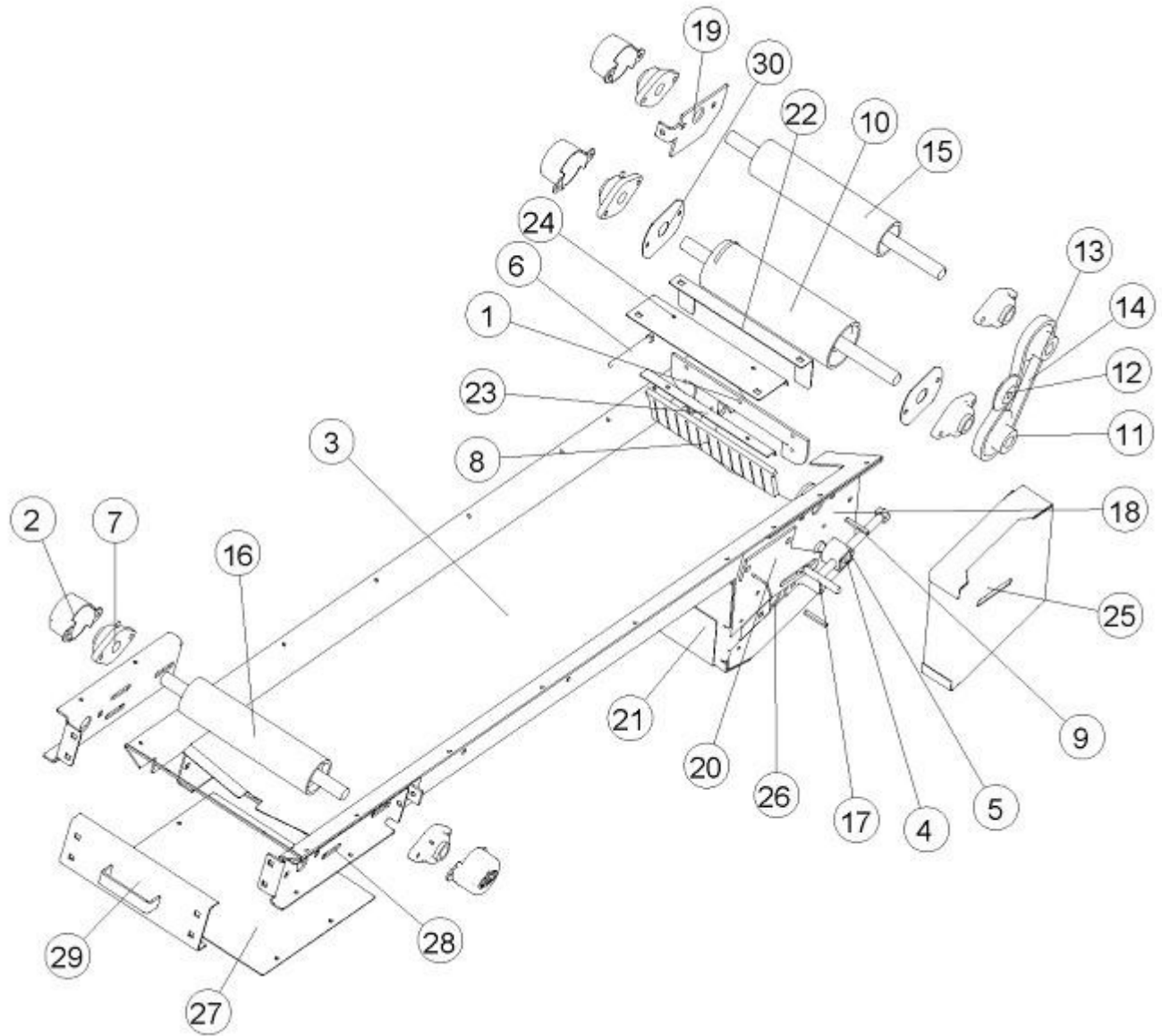

ITM	QTY	PART NO.	NAME
1	1	23122-03	FLOWGUARD, 8" CONV FOR 2" CLEAT
2	4	23150-04	COVER, 1" BEARING
3	1	23202-01	FRAME AS.
4	2	24114-01	NUT, SQUARE (5/8)
5	2	24115-03	SCREW, TENSIONING
6	1	24208-01	TAP BOLT (3/8 X 5)
7	6	24336-01	BEARING HOLDER
8	1	24348-01	BRUSH (12")
9	2	24356-01	KEY (1 IN SHAFT)
10	1	24393-00	DRUM AS. (4")
11	1	24395-01	SPROCKET, DRIVE (#50/16)
12	1	24396-01	SPROCKET, IDLER (#50/15)
13	1	24397-01	SPROCKET, DRIVE (#50/15)
14	1	24398-01	ROLLER CHAIN (50)
15	1	24399-00	DRUM AS.
16	1	24400-00	DRUM AS., TOP
17	1	24408-05	BOLT, CARRIAGE (1/2 X 3.5)
18	1	28001-00	HOUSING AS., LOWER
19	1	28007-01	BRACKET, BEARING
20	1	28016-01	BRACKET, IDLER SPROCKET
21	1	28031-00	DOOR AS.
22	1	28038-01	FLOWGUARD
23	1	28038-03	CLAMP, BRUSH
24	1	28038-05	BRUSH HOLDER
25	1	28053-00	GUARD, CHAIN
26	2	28204-01	SLIDE AS.
27	1	28210-03	SHIELD, LOWER GROUND
28	2	28344-00	BRACKET, LOWER BEARING
29	1	28345-01	LOWER BRACKET W/ HANDLE
30	2	60480-01	PLATE, BEARING
*	12"	24121-08	BELT, CRESC ENT TOP RUBBER
*	2'	24121-72	LACING, BELT
*	2	24121-73	PIN, RETAINING
*	1'	24121-75	PIN, LACING
*	1	28208-01	LH FLAP MID
*	1	28208-02	RH FLAP MID
			* ITEM NOT SHOWN

**23200-05
LOWER END GROUP SCT**

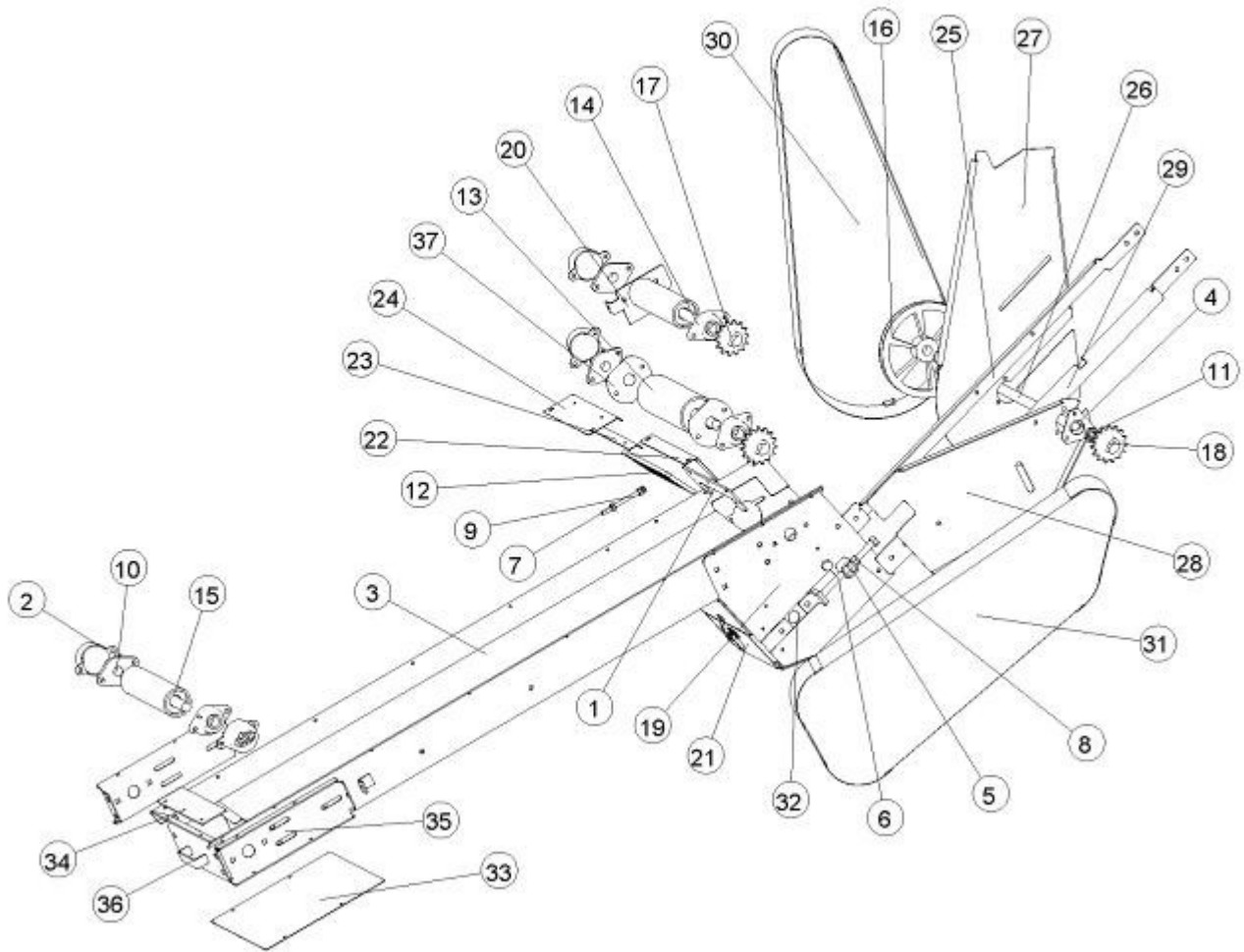

ITM	QTY	PART NO.	NAME
1	1	23122-03	FLOWGUARD, 8" CONV FOR 2" CLEAT
2	4	23150-04	COVER, 1" BEARING
3	1	23202-01	FRAME AS.
4	2	24009-01	BEARING HOLDER, SHAFT
5	2	24114-01	NUT, SQUARE (5/8)
6	2	24115-03	SCREW, TENSIONING
7	3	24133-01	NUT (3/8)
8	2	24139-01	NUT, 5/8-11 (SEE NOTE)
9	1	24208-01	TAP BOLT (3/8 X 5)
10	6	24336-01	BEARING HOLDER
11	2	24341-01	BEARING
12	1	24348-01	BRUSH (12")
13	1	24393-00	DRUM AS. (4")
14	1	24399-00	DRUM AS.
15	1	24400-00	DRUM AS., TOP
16	1	24405-05	PULLEY, 12 IN (B) (1")
17	1	24423-03	SPROCKET 14 TOOTH
18	2	24423-05	SPROCKET 15 TOOTH
19	1	28001-00	HOUSING AS., LOWER
20	1	28007-01	BRACKET, BEARING
21	1	28031-00	DOOR AS.
22	1	28038-01	FLOWGUARD
23	1	28038-03	CLAMP, BRUSH
24	1	28038-05	BRUSH HOLDER
25	1	28060-01	LEFT SIDE MOUNTING BRACKET
26	1	28062-01	JACKSHAFT
27	1	28063-01	PLATE, LEFT
28	1	28064-01	LOWER BELT GUARD BACK PLATE
29	1	28065-01	RIGHT SIDE MOUNTING BRACKET
30	1	28066-00	BELT GUARD
31	1	28067-00	CHAIN GUARD
32	2	28204-01	SLIDE AS.
33	1	28210-03	SHIELD, LOWER GROUND
34	1	28253-01	CROSS CHANNEL FLAP (12.5" X 3")
35	2	28344-00	BRACKET, LOWER BEARING
36	1	28345-01	LOWER BRACKET W/ HANDLE
37	2	60480-01	PLATE, BEARING
*	12	24121-08	BELT 12" RUBBER CRESCENT TOP
*	2'	24121-72	BELT, LACING
*	2	24121-73	PIN, REATINING
*	1'	24121-75	PIN, LACING
			* ITEM NOT SHOWN

21601-11 UPPER END GROUP

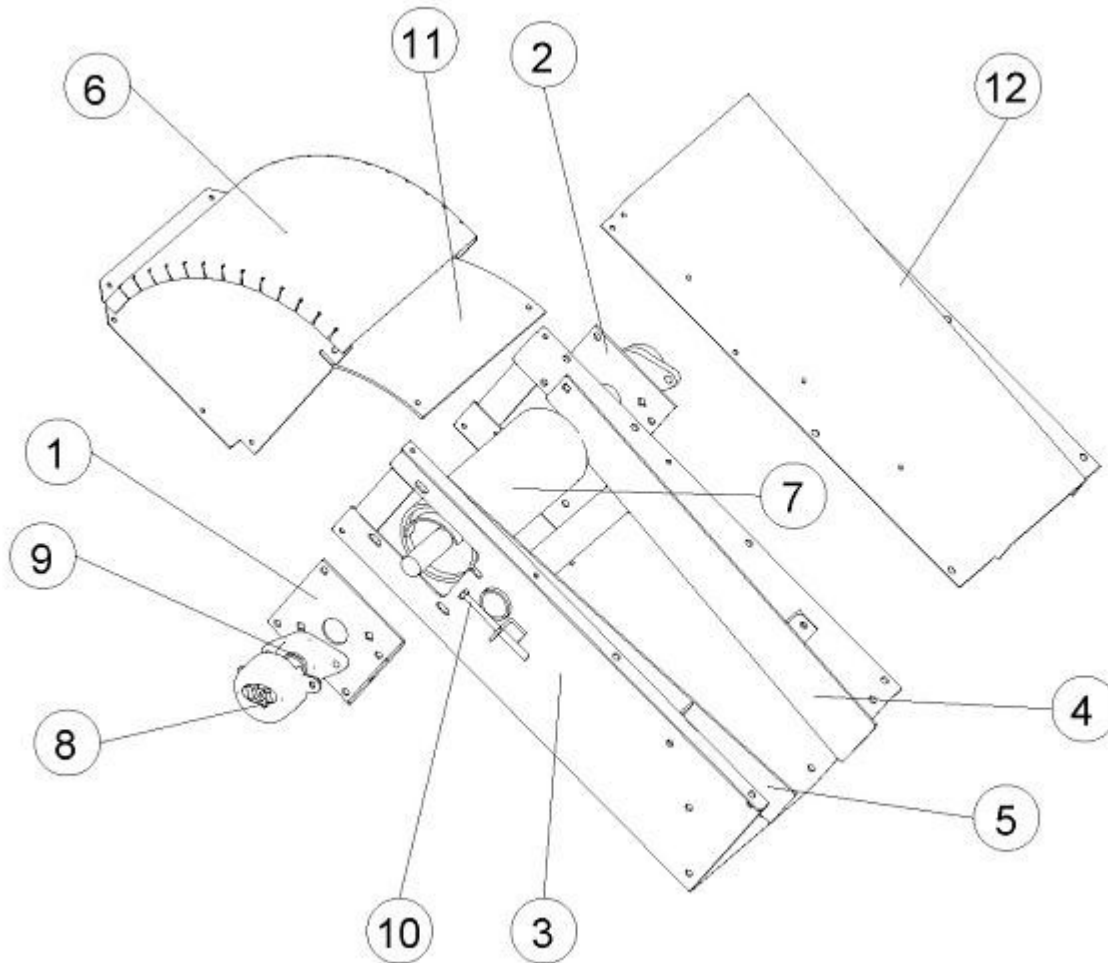

ITM	QTY	PART NO.	NAME
1	1	20012-00	PLATE AS, BEARING (LH)
2	1	20013-00	PLATE AS, BEARING (RH)
3	1	21511-00	DRIVE BOX AS.
4	1	21518-00	TRANSITION, RH
5	1	21519-00	TRANSITION, LH
6	1	21578-01	HOOD AS.
7	1	22107-00	DRUM ASSY, 5"
8	1	23150-02	COVER, 1 1/4" BEARING
9	2	24112-01	BEARING, 1-1/4" 2-BOLT FLANGE
10	1	24208-01	TAP BOLT (3/8 X 5)
11	1	24331-01	LINER
12	1	28014-01	COVER, TOP

21601-10 UPPER END GROUP SCT

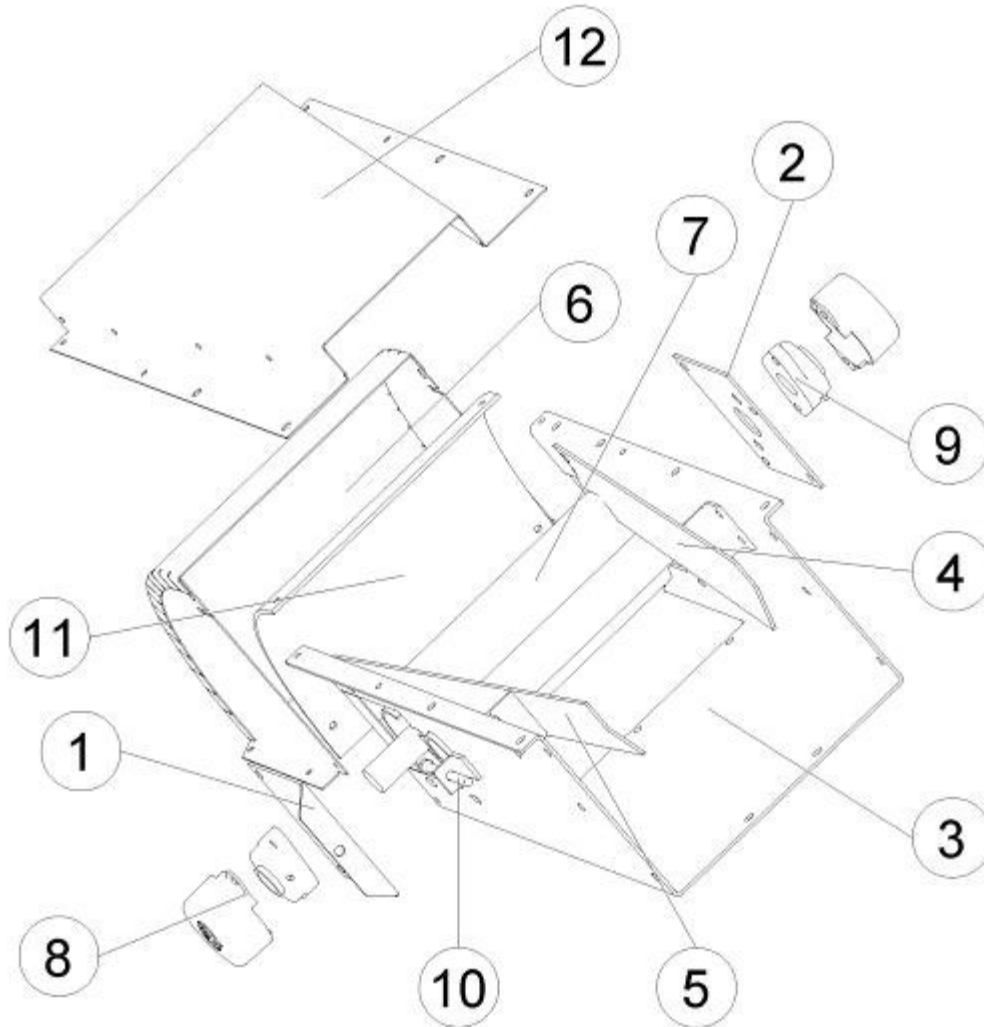

ITM	QTY	PART NO.	NAME
1	1	20012-00	PLATE AS, BEARING (LH)
2	1	20013-00	PLATE AS, BEARING (RH)
3	1	21511-00	DRIVE BOX AS.
4	1	21518-00	TRANSITION, RH
5	1	21519-00	TRANSITION, LH
6	1	21578-01	HOOD AS.
7	1	22106-00	DRUM AS. (CHAN 110-CSXV) 5"
8	2	23150-02	COVER, 1 1/4" BEARING
9	2	24112-01	BEARING FLANGE (J-DAY T-62G)
10	1	24208-01	TAP BOLT (3/8 X 5)
11	1	24331-01	LINER
12	1	28014-01	COVER, TOP

23205-03 HOPPER GROUP (COLLAPSIBLE)

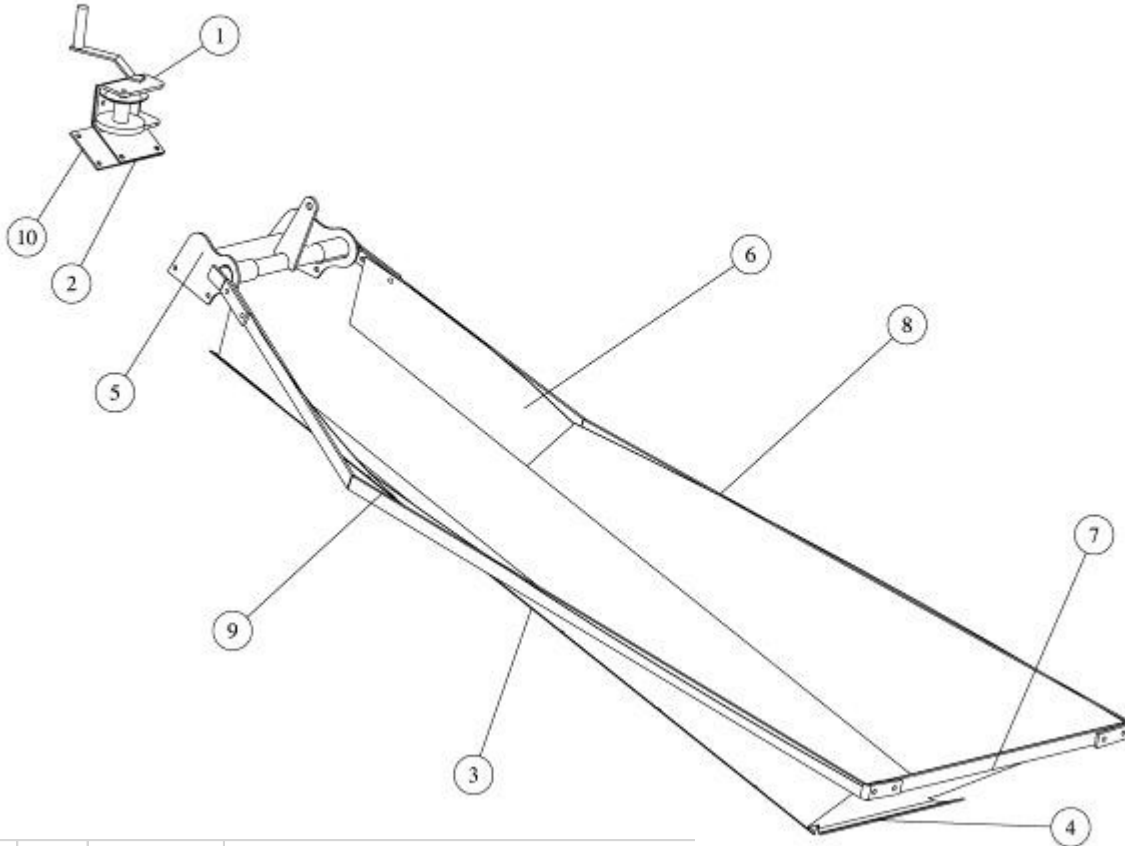

ITEM	QTY	PART NO.	NAME
1	1	21114-05	WINCH (WITH CRANK)
2	1	28085-01	BRACKET, WINCH
3	2	28252-01	FLAP, HOPPER SIDE
4	1	28207-01	FLAP, HOPPER
5	1	28211-00	MOUNTING AS.
6	1	28212-03	CANVAS, SERIAL #983 & LATER
	1	28212-01	CANVAS, SERIAL #982 & EARLIER
7	1	28213-01	BAR
8	1	28214-03	LH HOOP, SERIAL #983 & LATER
	1	28214-01	LH HOOP, SERIAL #982 & EARLIER
9	1	28214-04	RH HOOP, SERIAL #983 & LATER
	1	28214-02	RH HOOP, SERIAL #982 & EARLIER
10	1	28215-01	PLATE
*	1	28222-01	STRAP, HOPPER SIDE UC
*	1	28223-01	STRAP, HOPPER END UC
* ITEM NOT SHOWN			

24407-02 HYDRAULIC DRIVE GROUP

ITEM	QTY	PART NO.	NAME
1	1	20076-01	MOTOR MOUNT, TORQUE
2	1	20077-01	TUBE - GUARD
3	1	24364-01	MOTOR, HYDR., 5.9 CU. IN
4	1	24369-01	VALVE, CHECK
5	1	24473-01	COUPLER CLAMP, 1"

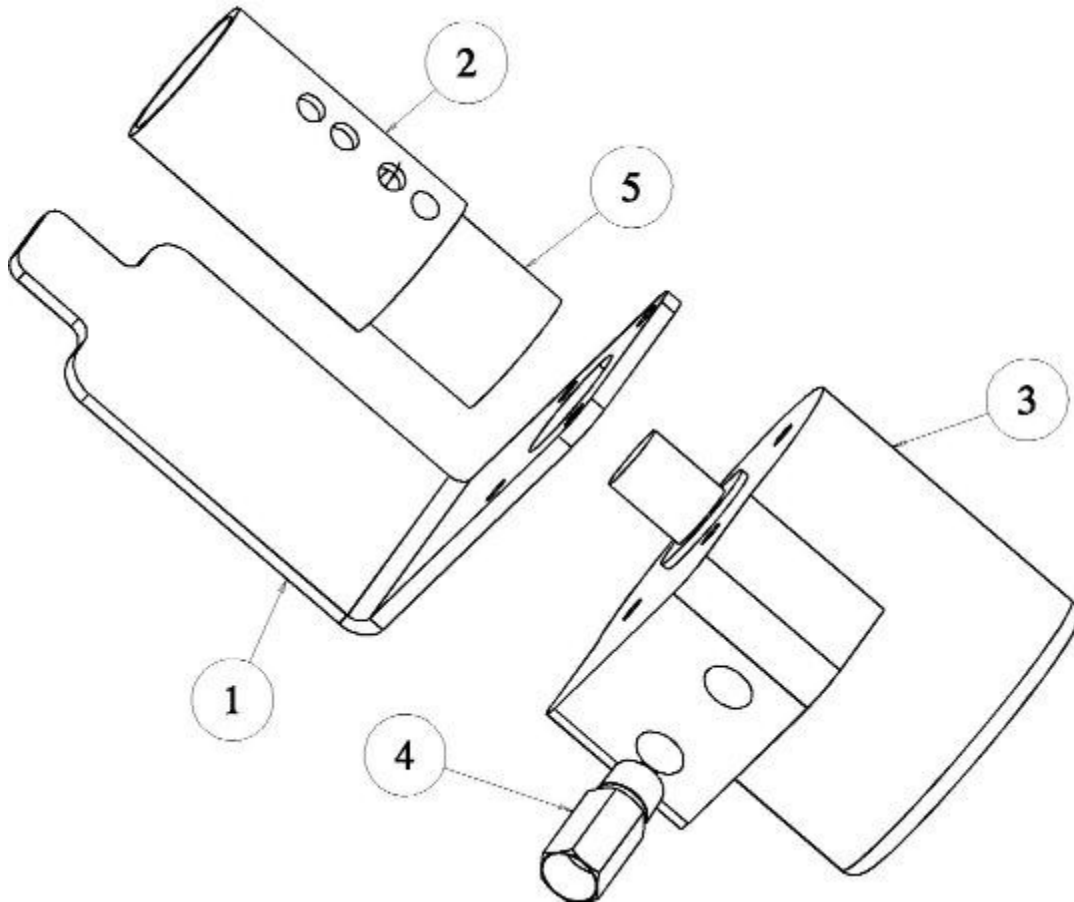

26120-01 MOTOR GROUP (ELECTRIC)

ITM	QTY	PART NO.	NAME
1	1	21049-01	BELT SHIELD
2	1	21090-01	MOTOR MOUNT
3	1	21520-00	TENSIONER, BELT
4	1	21549-01	BELT SHIELD AS.
5	1	24120-01	MOTOR, 5 HP 1PH
6	2	24358-03	V-BELT (BX56)
7	1	24338-01	PULLEY, 3 IN (2BK3")
8	1	24119-03	PULLEY, 18 IN (2BK18")
*	1	24177-01	KEY IN SHAFT
*	1	24171-01	TAPER L X 1 1/4" QD
* ITEM NOT SHOWN			

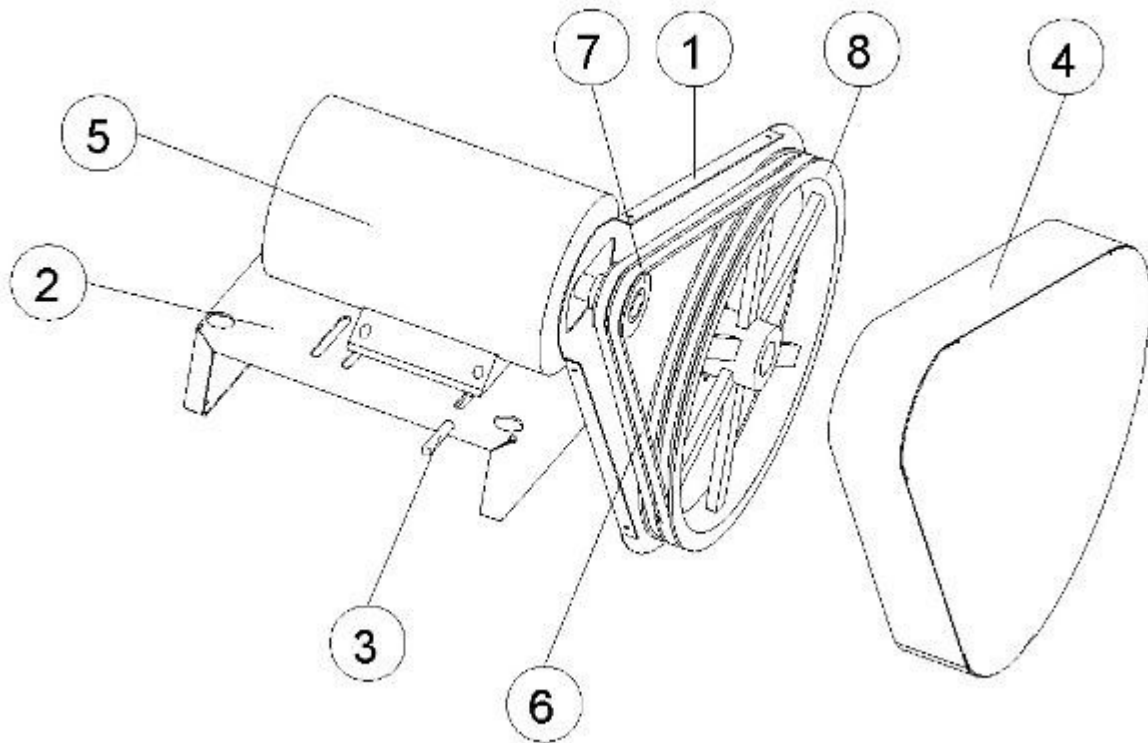

Dimensions

		25' MODEL		
Ø	20°	25°	30°	
A	33' 8"	32' 6"	31'	
B	31' 4"	30' 4"	28' 10"	
C	25' 4"	24' 5"	23' 4"	
D	13'	12' 5"	12'	
E	9' 7"	11' 10"	14'	

		30' MODEL		
Ø	20°	25°	30°	
A	37' 5"	36' 1"	34' 6"	
B	35' 1"	33' 10"	32' 4"	
C	29' 1"	28'	26' 9"	
D	17' 4"	16' 8"	15' 11"	
E	11' 1"	13' 8"	16' 8"	

		34' MODEL		
Ø	20°	25°	30°	
A	41' 2"	39' 9"	38'	
B	38' 10"	37' 6"	35' 10"	
C	32' 10"	31' 8"	30' 3"	
D	20' 10"	20' 3"	19' 3"	
E	12' 11"	15' 3"	18'	

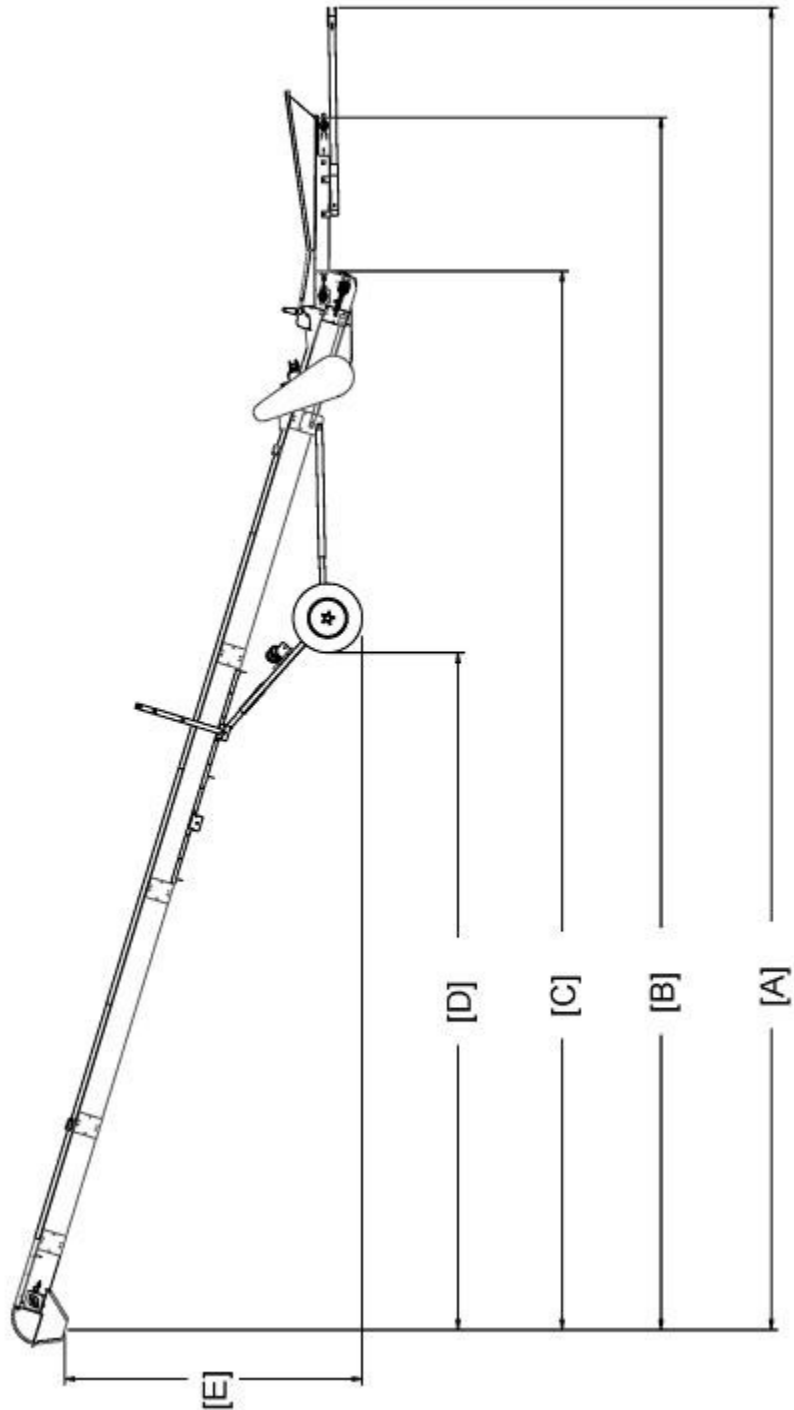

Specifications

1. Capacity

A. The capacities of conveyors varies greatly under varying conditions. The following factors play a role in the performance of the conveyor:

- Speed of belt
- Angle of operation
- Moisture content of commodity
- Percentage of foreign matter
- Methods of feeding
- Type of commodity

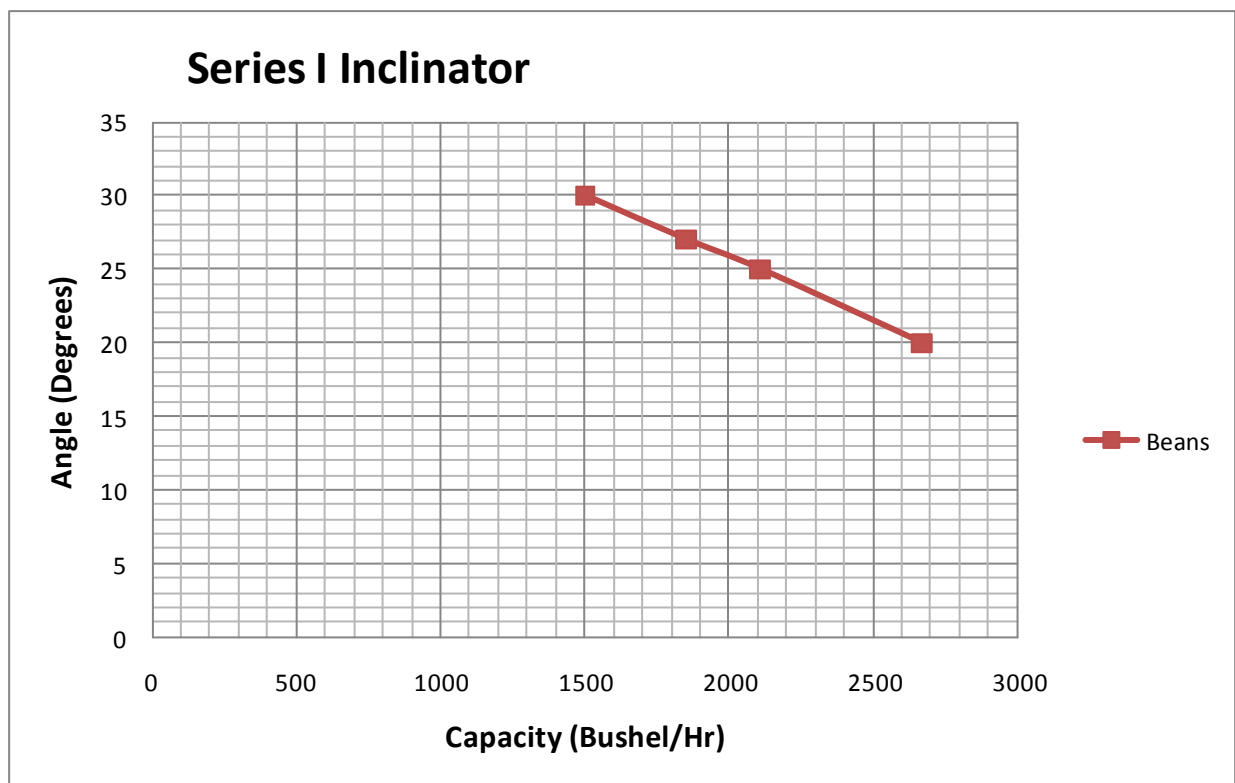

2. Drive Unit

- A. Electric motor, 5 hp
- B. Hydraulic motor, 5.9 cu.in./rev., 2000 psi, 8gpm
- C. Honda motor, 9 hp

3. Belt

Width: 12 in.

Upper belt: 2" Cleats on 6" spacing, molded rubber

Lower belt: Crescent top rubber belting

Belt speed:

Electric or Hydraulic: 400 fpm

SCT: 600 fpm